

## REVISION TRANSMITTAL

This sheet transmits Revision 2 to SB700-32-01 which:

- A. Removed step 2.D. to enter "TRUNNION SUPPORT ASSEMBLY" in the part name block.

**NOTE:** This revision replaces SB700-32-01 Rev. 1 in its entirety.

### REVISION COMPLIANCE

NO EFFECT. Airplanes previously modified by the service bulletin are not affected by this revision.

### LOG OF REVISIONS

Original Issue	February 5, 2021
Revision 1	April 13, 2021
Revision 2	August 2, 2021



**TITLE**

LANDING GEAR - INSTALLATION OF THE NOSE LANDING GEAR TRUNNION SUPPORT ASSEMBLY  
SERIAL PLACARDS

**EFFECTIVITY****MODEL**

700 (Citation Longitude)

**SERIAL NUMBERS**

-0001 thru -0030

The equivalent of this service document has been incorporated on production airplanes -0031 and On.

**REASON**

To install missing serial placards on the left and right nose landing gear support assemblies.

**DESCRIPTION**

This service document provides parts and instructions to install the left and right nose landing gear trunnion support serial placards.

**COMPLIANCE**

MANDATORY. This service document should be accomplished at the next scheduled maintenance period.

A service document published by Textron Aviation may be recorded as *completed* in an aircraft log only when the following requirements are satisfied:

- 1) The mechanic must complete all of the instructions in the service document, including the intent therein.
- 2) The mechanic must correctly use and install all applicable parts supplied with the service document kit. Only with written authorization from Textron Aviation can substitute parts or rebuilt parts be used to replace new parts.
- 3) The mechanic or airplane owner must use the technical data in the service document only as approved and published.
- 4) The mechanic or airplane owner must apply the information in the service document only to aircraft serial numbers identified in the *Effectivity* section of the document.
- 5) The mechanic or airplane owner must use maintenance practices that are identified as acceptable standard practices in the aviation industry and governmental regulations.

No individual or corporate organization other than Textron Aviation is authorized to make or apply any changes to a Textron Aviation-issued service document or flight manual supplement without prior written consent from Textron Aviation.

Textron Aviation is not responsible for the quality of maintenance performed to comply with this document, unless the maintenance is accomplished at a Textron Aviation-owned Service Center.

**APPROVAL**

Textron Aviation received FAA approval for the technical data in this publication that changes the airplane type design.

**FLIGHT CREW OPERATIONS**

No Changes

Original Issue - February 5, 2021  
Revision 2 - August 2, 2021

SB700-32-01  
Page 1 of 4

Textron Aviation Customer Service, P.O. Box 7706, Wichita, KS 67277, U.S.A. 1-316-517-5800

This document contains technical data and is subject to U.S. export regulations. This information has been exported from the United States in accordance with export administration regulations. Diversion contrary to U.S. law is prohibited. ECCN: 9E991

**MANDATORY****SB700-32-01****CONSUMABLE MATERIAL**

You must use the consumable materials that follow, or their equivalent, to complete this service document.

NAME	NUMBER	MANUFACTURER	USE
Adhesive Type I Class B	U470637	Textron Aviation Parts Distribution 7121 Southwest Boulevard Wichita, KS 67215	To bond parts.
Isopropyl Alcohol		Commercially Available	To clean parts.
Paint, Clear Polyurethane	AcryGlo CM0830080	Sherwin Williams 26300 Fargo Ave Bedford, OH 44146	Polyurethane Paint to protect placards.

**TOOLING**

No specialized tooling is required to complete this service document.

**WEIGHT AND BALANCE INFORMATION**

Negligible

**REFERENCES**

Citation Standard Practices Manual

**PUBLICATIONS AFFECTED**

None

**ACCOMPLISHMENT INSTRUCTIONS**

1. Prepare the airplane for maintenance.
  - A. Make sure that the airplane is electrically grounded.
  - B. Make sure that all switches are in the OFF/NORM position.
2. Use a steel stamp to identify the S4515-4 Placard as follows:
  - A. The aircraft serial number in the serial number block.
  - B. 7413215-3 in the part number block for the left side.
  - C. 7413215-4 in the part number block for the right side.
3. (Refer to Figure 1, Sheet 1.) Install the S4515-4 Placards on the 7413215 Trunnion Support Assemblies with U470637, Type I, Class B Adhesive. (Refer to the Citation Standard Practices Manual, Chapter 20, Adhesive and Solvent Bonding - Maintenance Practices.)
4. Apply a top coat of clear polyurethane paint over the placard.
5. Make an entry in the airplane logbook that states compliance and method of compliance with this service document.

**NOTE:** Textron Aviation recommends that compliance with all service documents is reported to a maintenance tracking system provider.

- Complete a record of compliance. (Maintenance Transaction Report, Log Book Entry, or other record of compliance.)
- Put a copy of the completed record of compliance in the airplane logbook.
- Send a copy of the completed record of compliance to the maintenance tracking system provider used.

A110400

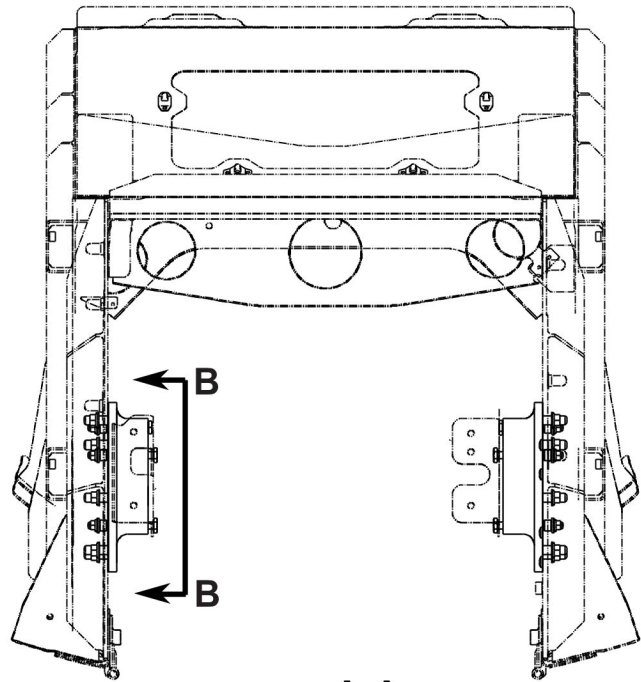
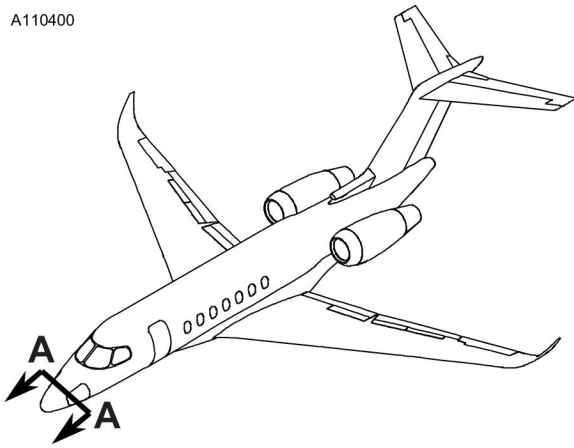

VIEW A-A

S4515-4  
Placard  
(1 Required)

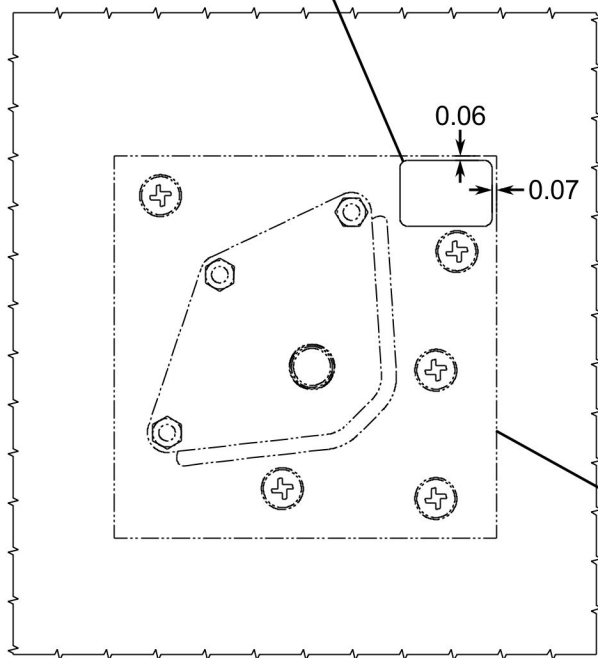

7413215  
Trunnion Support Assembly  
(Reference)

VIEW B-B

Left Side Shown, Right Side Opposite.

NOTE: All dimensions are in Inches.

7491215

Figure 1. Placard Installation (Sheet 1)

**MANDATORY****SB700-32-01****MATERIAL INFORMATION**

Order the part below to install this modification.

<b>NEW P/N</b>	<b>QUAN- TITY</b>	<b>KEY WORD</b>	<b>OLD P/N</b>	<b>INSTRUCTIONS/ DISPOSITION</b>
S4515-4	2	Placard		Install

\* Please contact Textron Aviation Parts Distribution for current cost and availability of parts listed in this service document. Phone at 1-800-835-4000 (Domestic) or 1-316-517-5603 (International).

For more information, please visit the TAPD Support & Aftermarket Account Management website at <https://ww2.txtav.com/Parts/Promos/TAPD>.

Based on availability and lead times, parts may require advanced scheduling.

**TITLE**

LANDING GEAR - INSTALLATION OF THE NOSE LANDING GEAR TRUNNION SUPPORT ASSEMBLY  
SERIAL PLACARDS

**TO:**

Cessna Model 700 (Citation Longitude) Aircraft Owner

**REASON**

To install missing serial placards on the left and right nose landing gear support assemblies.

**COMPLIANCE**

**MANDATORY.** This service document should be accomplished at the next scheduled maintenance period.

**LABOR HOURS****WORK PHASE**

Modification

**LABOR-HOURS**

1.0

**MATERIAL AVAILABILITY****PART NUMBER**

S4515-4

**AVAILABILITY**

\*

**COST**

\*

\* Please contact Textron Aviation Parts Distribution for current cost and availability of parts listed in this service document. Phone at 1-800-835-4000 (Domestic) or 1-316-517-5603 (International).

For more information, please visit the TAPD Support & Aftermarket Account Management website at <https://ww2.txtav.com/Parts/Promos/TAPD>.

Based on availability and lead times, parts may require advanced scheduling.

**WARRANTY**

This service document is *mandatory*. Eligible airplanes may qualify for parts and labor coverage to the extent noted in the *Labor Hours* and *Material Availability* sections of this document.

Original Issue - February 5, 2021  
Revision A - April 13, 2021

SB700-32-01  
Page 1 of 2

Textron Aviation Customer Service, P.O. Box 7706, Wichita, KS 67277, U.S.A. 1-316-517-5800

This document contains technical data and is subject to U.S. export regulations. This information has been exported from the United States in accordance with export administration regulations. Diversion contrary to U.S. law is prohibited. ECCN: 9E991

**Eligibility:** Airplanes identified within the serial number effectivity of this service document must have active Airframe warranty coverage on the original issue date of this document and the coverage must be active on the day the work is accomplished.

**Parts Coverage:** Textron Aviation-owned and Textron Aviation-authorized Service Facilities, operators, or other maintenance facilities may submit a claim for the parts required to accomplish this service document as defined in the *Material Availability* section of this document.

**Labor Coverage:** Textron Aviation-owned and Textron Aviation-authorized Service Facilities rated to perform maintenance on the specific model of Cessna Aircraft may submit a claim for the labor necessary to accomplish this service document as defined in the *Labor Hours* section of this document.

**Credit Application:** After this service document has been accomplished, a claim must be submitted to Textron Aviation within 30 days of the service document completion. Claims for compliance of this service document are to be filed as a W4 type claim.

Please submit your claim form online at [ww2.txtav.com/Parts](http://ww2.txtav.com/Parts) or email the completed Textron Aviation Claim Form to [warranty@txtav.com](mailto:warranty@txtav.com). If submitted on-line a Return Authorization will be provided. If a paper claim is submitted your claim will be entered into the system and a Return Authorization will be sent to you.

The Return Authorization must accompany any required return parts (see *Material Availability*), to the point of purchase.

Parts to be returned to Textron Aviation Parts Distribution should be forwarded to:

Textron Aviation Parts Distribution  
Warranty Administration  
285 South Greenwich Road  
Bldg B89, Docks 1-4  
Wichita, KS 67206  
USA

**Expiration:** February 28, 2023 (after this date the owner/operator assumes the responsibility for compliance costs)

Textron Aviation reserves the right to void continued airplane warranty coverage for the parts affected by this service document until the service document is accomplished.

**NOTE:** As a convenience, service documents are now available online to all our customers through a simple, free-of-charge registration process. If you would like to sign up, please visit the Customer Access link at [www.txtavsupport.com](http://www.txtavsupport.com) to register.