

REVISION TRANSMITTAL

This sheet transmits Revision 1 to SB680-34-41 which:

- A. Removed the instructions to remove the 124282-2100 Configuration Module from Step 2.
- B. Removed the instructions to install the 124282-2200 Configuration Module from Step 2.
- C. Removed the Adjustment/Test for the Litef LCR-100N from Step 2.
- D. Added Step 3.
- E. Removed the 124282-2200 from the Material Information Section.
- F. Removed 124282-2200 Configuration Module from the illustration.

NOTE: This revision replaces Original Issue of SB680-34-41 in its entirety.

NOTE: This transmittal sheet provides a complete description of the changes made by this revision, except for editorial changes.

REVISION COMPLIANCE

NO EFFECT. Airplanes previously modified by this service bulletin are not affected by this revision.

LOG OF REVISIONS

Original Issue	April 1, 2021
Revision 1	June 28, 2021

TITLE

NAVIGATION - INSTALLATION OF DUAL LITEF HYBRID NAVIGATOR UNITS AND RNP AR = 0.3 SOFTWARE

EFFECTIVITY

MODEL	SERIAL NUMBERS
680 (Citation Sovereign+)	-0501 thru -0600

NOTE: Textron Aviation-owned Service Centers are the only facilities that can complete this service document.

NOTE: Service Bulletin 680-34-39, Navigation - Garmin G5000 Software Update to Garmin 4.8, Version A2, Initial Release or later must be completed before or in conjunction with this service bulletin.

REASON

To provide an option for the operators to install Dual Litef Hybrid Navigator Units and RNP AR = 0.3 Software.

DESCRIPTION

This service document provides parts and instructions to install Litef Dual Hybrid Navigator Units and RNP AR = 0.3 Software.

NOTE: This service bulletin will require the following software:

- 010-01249-A2 - Garmin 4.8, Version A2 Software Base Loader Card (Existing)

COMPLIANCE

OPTIONAL. This service document can be accomplished at the discretion of the owner.

A service document published by Textron Aviation may be recorded as *completed* in an aircraft log only when the following requirements are satisfied:

- 1) The mechanic must complete all of the instructions in the service document, including the intent therein.
- 2) The mechanic must correctly use and install all applicable parts supplied with the service document kit. Only with written authorization from Textron Aviation can substitute parts or rebuilt parts be used to replace new parts.
- 3) The mechanic or airplane owner must use the technical data in the service document only as approved and published.
- 4) The mechanic or airplane owner must apply the information in the service document only to aircraft serial numbers identified in the *Effectivity* section of the document.
- 5) The mechanic or airplane owner must use maintenance practices that are identified as acceptable standard practices in the aviation industry and governmental regulations.

No individual or corporate organization other than Textron Aviation is authorized to make or apply any changes to a Textron Aviation-issued service document or flight manual supplement without prior written consent from Textron Aviation.

Textron Aviation is not responsible for the quality of maintenance performed to comply with this document, unless the maintenance is accomplished at a Textron Aviation-owned Service Center.

Original Issue - April 1, 2021
Revision 1 - June 28, 2021

SB680-34-41
Page 1 of 8

Textron Aviation Customer Service, P.O. Box 7706, Wichita, KS 67277, U.S.A. 1-316-517-5800

This document contains technical data and is subject to U.S. export regulations. This information has been exported from the United States in accordance with export administration regulations. Diversion contrary to U.S. law is prohibited. ECCN: 9E991

APPROVAL

Textron Aviation received FAA approval for the technical data in this publication that changes the airplane type design.

Textron Aviation received EASA approval for the technical data in this publication that changes the airplane type design.

FLIGHT CREW OPERATIONS

Refer to the attached *Flight Crew Operations Summary*.

CONSUMABLE MATERIAL

No specialized consumable materials are required to complete this service document.

TOOLING

No specialized tooling is required to complete this service document.

WEIGHT AND BALANCE INFORMATION

Negligible

REFERENCES

Cessna Model 680 Maintenance Manual

Citation Standard Practices Manual

PUBLICATIONS AFFECTED

Cessna Model 680 Maintenance Manual

Cessna Model 680 Illustrated Parts Catalog

Cessna Model 680 (Sovereign+) Airplane Flight Manual (501 and On) (68FMA)

ACCOMPLISHMENT INSTRUCTIONS

1. Prepare the airplane for maintenance.
 - A. Make sure that the airplane is electrically grounded.
 - B. Make sure that all switches are in the OFF/NORM position.
 - C. Disconnect electrical power from the airplane.
 - (1) Disconnect the airplane battery.
 - (2) Disconnect external electrical power.
 - D. Attach maintenance warning tags to the battery and external power receptacle that have **"DO NOT CONNECT ELECTRICAL POWER - MAINTENANCE IN PROGRESS"** written on them.
2. (Refer to Figure 1, Detail A.) Install Upgraded Dual Litef Hybrid Navigator Units as follows:
 - A. On aircraft with 145130-3000 LCR-100N Hybrid Navigator Units installed, do the steps that follow:
 - (1) Remove two 145130-3000 LCR-100N Hybrid Navigator Units (UN303 left, UN304 right). (Refer to Cessna Model 680 Maintenance Manual, Chapter 34, Litef LCR-100N Hybrid Navigation System (HNS) - Maintenance Practices (Airplanes 0501 and ON)).
 - (2) Go to Step 2.C.
 - B. On aircraft with S3100-604 LCR-100N Hybrid Navigator Units installed, do the steps that follow:
 - (1) Remove two S3100-604 LCR-100N Hybrid Navigator Units (UN303 left, UN304 right). (Refer to Cessna Model 680 Maintenance Manual, Chapter 34, Litef LCR-100N Hybrid Navigation System (HNS) - Maintenance Practices (Airplanes 0501 and ON)).

- C. Install two S3100-645 Litef LCR-100N Hybrid Navigator Units (UN303 left, UN304 right). (Refer to Cessna Model 680 Maintenance Manual, Chapter 34, Litef LCR-100N Hybrid Navigation System (HNS) - Maintenance Practices (Airplanes 0501 and ON)).
- D. Load the Hybrid Navigator (FK635P - Hybrid Navigator) file as follows:
- (1) Connect the airplane battery.
 - (2) Remove the maintenance warning tags attached to the battery and external power receptacle that have **"DO NOT CONNECT ELECTRICAL POWER - MAINTENANCE IN PROGRESS"**
 - (3) Connect external electrical power to the aircraft.
 - (4) If necessary, adjust the power unit to 28 VDC ($\pm .05$) VDC.
 - (5) Turn the L Primary Flight Display (PFD), R PFD and the Multi-Function Display (MFD) dimmer knobs fully counter-clockwise to the OFF position.
 - (6) Disengage the circuit breakers (CB) that follow:
 - L PFD GTC (Left CB Panel - E4)
 - MFD L GTC (Left CB Panel - N3)
 - MFD R GTC (Right CB Panel - MM4)
 - R PFD GTC (Right CB Panel - NN4)
 - (7) Push and release the EXT PWR switch to the ON position.
 - (8) Make sure that the BUS TIE switch on the left switch panel shows CLOSED.
 - (9) Make sure that the L ELEC and the R ELEC switch on the left switch panel show NORM.
 - (10) Set the L AVN and the R AVN switch on the left switch panel to the ON position.
 - (11) Install the 010-01249-A2 - Garmin 4.8, Version A2 Software Base Loader Card into the upper Secure Digital (SD) card slot of the R PFD.
 - (12) Make sure the L PFD, R PFD and MFD and all Garmin Touch Controllers (GTC) are not on.
 - (13) Push and hold the right inner knob on the left PFD GTC and engage the L PFD GTC CB E4.
 - (a) Release the right inner knob on the left PFD GTC when INITIALIZING message shows on the GTC screen.
 - (14) Push and hold the right knob on the left MFD GTC and engage the MFD L GTC circuit breaker (N3).
 - (a) Release the right knob on the left MFD GTC when INITIALIZING message shows on the GTC screen.
 - (15) Push and hold the right knob on the right MFD GTC and engage the MFD R GTC circuit breaker (MM4).
 - (a) Release the right knob on the right MFD GTC when INITIALIZING message shows on the GTC screen.
 - (16) Push and hold the right knob on the right PFD GTC and engage the R PFD GTC circuit breaker (NN4).
 - (a) Release the right knob on the right PFD GTC when INITIALIZING message shows on the GTC screen
 - (17) After initialization of the GTCs, make sure all GTCs show the CONFIG MODE screen.
 - (18) Turn the R PFD dimmer knob clockwise to the full bright position.
 - (19) After the initialization of the R PFD, make sure the INITIALIZING SYSTEM message shows in the top left corner of the R PFD.

NOTE: The R PFD will automatically start to load the software.

- (20) When the software load is complete, the SYSTEM STATUS page will show at the top of R PFD.
- (21) Remove the 010-01249-A2 Garmin 4.8, Version A2 Software Base Loader Card from the R PFD.
- (22) Install the 010-01249-A2 Garmin 4.8, Version A2 Software Base Loader Card in the MFD.
- (23) Turn the MFD dimmer knob clockwise to the full bright position.
- (24) After the initialization of the MFD, make sure the INITIALIZING SYSTEM message shows in the top left corner of the MFD.

NOTE: The MFD will automatically start to load the software.

- (25) When the software load is complete, the SYSTEM UPLOAD page will show at the top of MFD.
- (26) Remove the 010-01249-A2 Garmin 4.8, Version A2 Software Base Loader Card from the MFD.
- (27) Install the 010-01249-A2 Garmin 4.8, Version A2 Software Base Loader Card in the L PFD.
- (28) Turn the L PFD dimmer knob clockwise to the full bright position.
- (29) After the initialization of the L PFD, make sure the INITIALIZING SYSTEM message shows in the top left corner of the L PFD.

NOTE: The L PFD will automatically start to load the software.

- (30) When the software load is complete, the SYSTEM UPLOAD page will show at the top of L PFD.

NOTE: Loading the FK635 - Hybrid Navigation enables both the Hybrid Navigation option as well as the RNP AR = 0.3 software.

- (31) Load the Hybrid Navigation (FK635P - Hybrid Navigation) option as follows:
 - (a) Push and release the right knob on the pilot's right GTC to activate the cursor.
 - (b) Turn the right inner knob on the pilot's right GTC to the right and highlight 'Options' in the GROUP field.
 - (c) Select Enter on the GTC.
 - (d) Turn the right outer knob on the pilot's right GTC to the right until the cursor is in the ITEM field.
 - (e) Turn the right inner knob on the pilot's right GTC and highlight 'FK635P- Hybrid Nav' in the ITEM field.
 - (f) Select Enter on the GTC.
 - (g) Using the Left and Right arrows on the pilot's right GTC, highlight LOAD at the bottom of the display.
 - (h) Select the Select button on the pilot's right GTC.
 - (i) Monitor the configuration load.
 - 1 Select Enter when the loading is complete to acknowledge the 'Upload and Crossfill Complete' window.

E. Do the Aircraft Configuration Verification:

- (1) Confirm the AIRCRAFT ID as follows:
 - (a) Turn the inner knob on the pilot's right GTC to the right until the CONFIGURATION MANAGER screen shows.
 - (b) At the top of the display, make sure that the two AIRCRAFT ID numbers match.

- (c) If they do not match, do as follows:
- 1 Using the left and right arrows on the pilot's GTC, highlight CNFRM CFG at the bottom of the display.
 - 2 Select the Select button on the pilot's right GTC.
NOTE: A window will show that states 'Confirm configuration as expected configuration?'
 - 3 Using the left and right arrows on the pilot's right GTC to highlight OK.
 - 4 Select the Enter on the GTC.
 - 5 At the top of the display, make sure the two AIRCRAFT ID numbers in the EXPECTED CONFIGURATION ID column and the ACTUAL CONFIGURATION ID column match.
- (2) Make sure the Configuration is correct as follows:
- (a) Push the inner knob on the pilot's right GTC to activate the cursor.
 - (b) Use the outer knob on the pilot's right GTC to scroll through the list of LRU's in the CONFIGURATION ITEMS box.
 - 1 Make sure that both columns for each LRU shows Valid (in green) except for GSR1 and GSR2 which if installed, will show 'Status Not Supported' (in gray).
- F. Check the Transaction Log as follows:
- (1) Push and release the right knob on the pilot's right GTC to deactivate the cursor.
 - (2) Turn the right inner knob on the pilot's right GTC to the right until the Transaction Log screen shows.
 - (a) Make sure there is a line entry for FK635P - Hybrid Nav option.
 - (b) Make sure there is a (green) pass in the Status column.
 - (c) Make sure there is not a line entry marked CNFM CFG with (amber) 'FLEET ID UPDATED' in the Status column.
 - 1 If an (amber) 'FLEET ID UPDATED' is present, software and configuration must be reloaded.
NOTE: It is acceptable to have a line entry of CNFM CFG with 'AIRCRAFT ID UPDATED' (in white) in the STATUS column or no line entry with CNFM CFG.
NOTE: Make sure that there are no entries with an amber or red indication in the STATUS column. Green and white are the only acceptable colors for status.
 - (3) Turn aircraft electrical power off. (Refer to Cessna Model 680 Maintenance Manual, Chapter 24, External Electrical Power - Maintenance Practices.)
 - (4) Remove the 010-01249-A2 Garmin 4.8, Version A2 Software Base Loader Card from the upper slot of the L PFD.
 - (5) Turn aircraft electrical power on. (Refer to Cessna Model 680 Maintenance Manual, Chapter 24, External Electrical Power - Maintenance Practices.)
- G. Do the Final Verification/Return to Service as follows:
- (1) Turn aircraft electrical power off. (Refer to Cessna Model 680 Maintenance Manual, Chapter 24, External Electrical Power System - Description and Operation.)
 - (2) Remove the 010-01249-A2 Garmin 4.8, Version A2 Software Base Loader Card) from the upper slot of the L PFD.

- (3) Turn aircraft electrical power on. (Refer to Cessna Model 680 Maintenance Manual, Chapter 24, External Electrical Power System - Description and Operation.)
- (4) Check the LRU status as follows:
 - (a) Select Home on the pilot's right GTC.
 - (b) Select Utilities.
 - (c) Select Setup.
 - (d) Select Avionics Status.
 - (e) Select the LRU Info tab.
 - 1 Make sure all the LRU's show a green check mark.
- (5) Check the Message Status as follows:
 - (a) Select MSG on the pilot's right GTC.
 - 1 Make sure no DB Mismatch message shows.
 - 2 Make sure no Manifest message shows.
 - 3 Make sure no Config message shows
 - (b) Make sure the AVIONICS CONFIG CAS message is not shown.
 - (c) Disconnect external electrical power from the aircraft.
3. Do the Litef LCR-100N Hybrid Navigator Operational Check. (Refer to Cessna Model 680 Maintenance Manual, Chapter 34, Litef LCR-100N Hybrid Navigation System (HNS) - Adjustment/Test.)
4. Update the 680 Sovereign+ (0501 and On) FAA Approved Airplane Flight Manual (68FMA).
 - A. Make sure that Supplement 5 Original Issue or later is inserted into the 680 Citation Sovereign+ (0501 and On) FAA Approved Airplane Flight Manual (68FMA).
5. Make sure the flight crew receives the *Flight Crew Operations Summary*, which shows the operational changes that are a result of the accomplishment of this service bulletin.
6. Make an entry in the airplane logbook that states compliance and method of compliance with this service document.

NOTE: Textron Aviation recommends that compliance with all service documents is reported to a maintenance tracking system provider.

- Complete a record of compliance. (Maintenance Transaction Report, Log Book Entry, or other record of compliance.)
- Put a copy of the completed record of compliance in the airplane logbook.
- Send a copy of the completed record of compliance to the maintenance tracking system provider used.

A110595

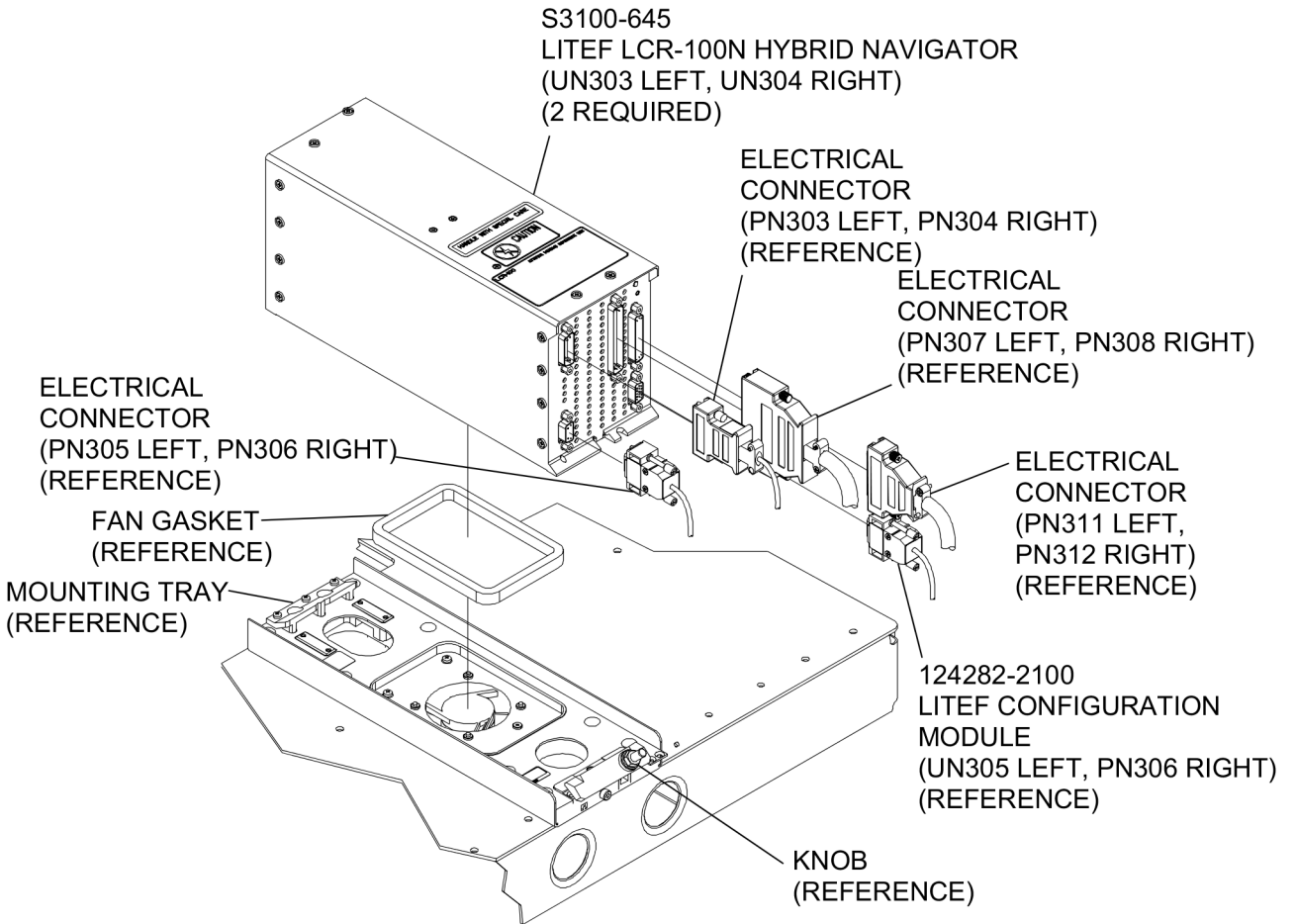
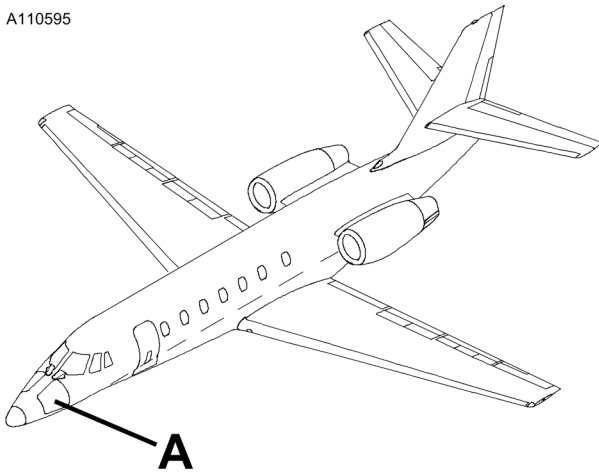

DETAIL A

LEFT SIDE SHOWN, RIGHT SIDE TYPICAL

Figure 1. Installation of the Dual Litef Hybrid Navigator Units and Configuration Modules (Sheet 1)

6910T1001
 A7418T019-1

MATERIAL INFORMATION

Order the parts below to install this modification.

NEW P/N	QUANTITY	KEY WORD	OLD P/N	INSTRUCTIONS/ DISPOSITION
S3100-645	2	Litef LCR-100N Hybrid Navigator Unit	145130-3000 or S3100-604	Return to Textron Aviation for exchange

The existing S3100-604 or 145130-3000 LCR-100N Hybrid Navigator Units may be returned to Textron Aviation Parts Distribution, Warranty Administration, 285 South Greenwich Road, Bldg B89, Docks 1-4, Wichita, KS 67206, USA, and exchanged for an upgraded unit. Due to limited availability, advance scheduling is required, please expedite the return of the removed part.

* Please contact Textron Aviation Parts Distribution for current cost and availability of parts listed in this service document. Phone at 1-800-835-4000 (Domestic) or 1-316-517-5603 (International). Send email to: parts@txtav.com.

Based on availability and lead times, parts may require advanced scheduling.

FLIGHT CREW OPERATIONS SUMMARY

SB680-34-41 *Navigation - Installation of Dual LITEF Hybrid Navigator Units and RNP AR = 0.3 Software*

This summary provides additional information for the flight crew regarding operational changes as a result of accomplishment of this service bulletin. Please remove this summary from the service bulletin and give it to the flight crew. This summary is *informational only* and does not supersede any information in the FAA-approved airplane flight manual.

- New functionality with Dual LITEF Hybrid Navigation Units and RNP AR=0.3 Software (Does not include button labeling or graphic changes if functions remain the same. Some functionality may require optional software.)
 - RNP AR approach capability to minimums ≥ 0.3 and missed approach > 1.0 .
 - Inertial navigation backup in the event of GNSS failure.

TITLE

NAVIGATION - INSTALLATION OF DUAL LITEF HYBRID NAVIGATOR UNITS AND RNP AR = 0.3 SOFTWARE

TO:

Cessna Model 680+ Aircraft Owner

REASON

To provide an option for the operators to install Dual Litef Hybrid Navigator Units and RNP AR = 0.3 Software.

COMPLIANCE

OPTIONAL. This service document can be accomplished at the discretion of the owner.

LABOR HOURS

WORK PHASE	LABOR-HOURS
Modification	As Necessary
Test and Inspection	As Necessary

MATERIAL AVAILABILITY

Order the parts below to install this modification.

NEW P/N	QUANTITY	KEY WORD	OLD P/N	INSTRUCTIONS/ DISPOSITION
S3100-645EX	2	Litef LCR- 100N Hybrid Navigator Unit	S3100-604 or 145130-3000	Return to Textron Aviation for exchange

The existing S3100-604 or 145130-3000 LCR-100N Litef LCR - 100N Hybrid Navigator Unit may be returned to Textron Aviation Parts Distribution, Warranty Administration, 285 South Greenwich Road, Bldg B89, Docks 1-4, Wichita, KS 67206, USA, and exchanged for an upgraded unit. Due to limited availability, advance scheduling is required, please expedite the return of the removed part.

* Please contact Textron Aviation Parts Distribution for current cost and availability of parts listed in this service document. Phone at 1-800-835-4000 (Domestic) or 1-316-517-5603 (International). Send email to: parts@txtav.com.

Based on availability and lead times, parts may require advanced scheduling.

WARRANTY

None

NOTE: As a convenience, service documents are now available online to all our customers through a simple, free-of-charge registration process. If you would like to sign up, please visit the Customer Access link at www.txtavsupport.com to register.

Original Issue - April 1, 2021
Revision A - June 28, 2021

SB680-34-41
Page 1 of 1

Textron Aviation Customer Service, P.O. Box 7706, Wichita, KS 67277, U.S.A. 1-316-517-5800

This document contains technical data and is subject to U.S. export regulations. This information has been exported from the United States in accordance with export administration regulations. Diversion contrary to U.S. law is prohibited. ECCN: 9E991

