

## REVISION TRANSMITTAL

This sheet transmits Revision 1 to SB700-49-01, which:

- A. Added Figure 1, Sheets 1 thru 3.

**NOTE:** This revision replaces original issue of SB700-49-01 in its entirety.

**NOTE:** This transmittal sheet provides a complete description of the changes made by this revision, except for editorial changes.

### REVISION COMPLIANCE

NO EFFECT. Airplanes previously modified by this service bulletin are not affected by this revision.

### LOG OF REVISIONS

|                |                  |
|----------------|------------------|
| Original Issue | February 2, 2021 |
| Revision 1     | May 14, 2021     |



**TITLE**

AUXILIARY POWER - MODIFICATION OF THE AUXILIARY POWER UNIT (APU) STARTING SYSTEM

**EFFECTIVITY****MODEL**

700 (Citation Longitude)

**SERIAL NUMBERS**

-0004, -0008 thru -0032, -0034 thru -0041

The equivalent of this service document has been incorporated on production airplanes -0042 and On.

**REASON**

**NOTE:** Service Bulletin SB700-42-01 - Garmin G5000 Software Update to System Software Version 2257.58 Original Issue or later must be completed prior to or in conjunction with this service bulletin.

To change the APU start sequence up to thirty-one thousand feet with both engine driven generators ON and without engine N2 speed limitations.

**DESCRIPTION**

This service document provides parts and instructions to change the APU start sequence up to thirty-one thousand feet with both engine driven generators ON and without engine N2 speed requirements.

**COMPLIANCE**

DISCRETIONARY. This service document can be accomplished at the discretion of the owner.

A service document published by Textron Aviation may be recorded as *completed* in an aircraft log only when the following requirements are satisfied:

- 1) The mechanic must complete all of the instructions in the service document, including the intent therein.
- 2) The mechanic must correctly use and install all applicable parts supplied with the service document kit. Only with written authorization from Textron Aviation can substitute parts or rebuilt parts be used to replace new parts.
- 3) The mechanic or airplane owner must use the technical data in the service document only as approved and published.
- 4) The mechanic or airplane owner must apply the information in the service document only to aircraft serial numbers identified in the *Effectivity* section of the document.
- 5) The mechanic or airplane owner must use maintenance practices that are identified as acceptable standard practices in the aviation industry and governmental regulations.

No individual or corporate organization other than Textron Aviation is authorized to make or apply any changes to a Textron Aviation-issued service document or flight manual supplement without prior written consent from Textron Aviation.

Textron Aviation is not responsible for the quality of maintenance performed to comply with this document, unless the maintenance is accomplished at a Textron Aviation-owned Service Center.

**APPROVAL**

Textron Aviation received FAA approval for the technical data in this publication that changes the airplane type design.

Original Issue - February 2, 2021  
Revision 1 - May 14, 2021

SB700-49-01  
Page 1 of 10

Textron Aviation Customer Service, P.O. Box 7706, Wichita, KS 67277, U.S.A. 1-316-517-5800

This document contains technical data and is subject to U.S. export regulations. This information has been exported from the United States in accordance with export administration regulations. Diversion contrary to U.S. law is prohibited. ECCN: 9E991

**FLIGHT CREW OPERATIONS**

Refer to the attached *Flight Crew Operations Summary*.

**CONSUMABLE MATERIAL**

No specialized consumable materials are required to complete this service document.

**TOOLING**

| NAME                                 | NUMBER    | MANUFACTURER   | USE   |
|--------------------------------------|-----------|--|---|
| Nose Landing Gear Simulator Test Box | 6988012-7 | Textron Aviation Parts Distribution<br>7121 Southwest Boulevard<br>Wichita, KS 67215 | To simulate the airplane on the ground or in the air. |
| Main Landing Gear Simulator Test Box | 8288001-1 | Textron Aviation Parts Distribution<br>7121 Southwest Boulevard<br>Wichita, KS 67215 | To simulate the airplane on the ground or in the air. |

**WEIGHT AND BALANCE INFORMATION**

Negligible

**REFERENCES**

Cessna Model 700 Maintenance Manual  
 Cessna Model 700 Electrical Wiring Interconnect System Manual  
 Citation Standard Practices Manual

**PUBLICATIONS AFFECTED**

Cessna Model 700 Wiring Diagram Manual  
 Citation Longitude FAA Approved Airplane Flight Manual Volumes 1, 2 and 3.

**ACCOMPLISHMENT INSTRUCTIONS**

1. Prepare the airplane for maintenance.
  - A. Make sure that the airplane is electrically grounded.
  - B. Make sure that all switches are in the OFF/NORM position.
  - C. Disconnect electrical power from the airplane.
    - (1) Disconnect the airplane batteries.
    - (2) Disconnect external electrical power.
  - D. Attach maintenance warning tags to the battery and external power receptacle that have **"DO NOT CONNECT ELECTRICAL POWER - MAINTENANCE IN PROGRESS"** written on them.
2. Do the APU starting system modification as follows:
  - A. Remove the left DC power junction box cover as follows:
    - (1) Loosen the fasteners that attach the left DC power junction box cover.
    - (2) Remove the cover from the left DC power junction box.
  - B. Remove left emergency power junction box cover as follows:
    - (1) Loosen the fasteners that attach the left emergency power junction box cover.
    - (2) Remove the cover from the left emergency power junction box.
  - C. Remove the right DC power junction box cover as follows:
    - (1) Loosen the fasteners that attach the right DC power junction box cover.

- (2) Remove the cover from the right DC power junction box.
- D. Remove the Printed Circuit Boards (PCB) as follows:
  - (1) Remove the 7468185-5 Power Distribution PCB Assembly (NZ102) left DC power junction box. (Refer to Cessna Model 700 Maintenance Manual, Chapter 24, DC Power Junction Box Printed Circuit Board (PCB) - Removal/Installation.)
  - (2) Remove the 7468185-5 Power Distribution PCB Assembly (NZ202) right DC power junction box. (Refer to Cessna Model 700 Maintenance Manual, Chapter 24, DC Power Junction Box Printed Circuit Board (PCB) - Removal/Installation.)
  - (3) Remove the 7468186-1 Auxiliary Power Distribution PCB Assembly (NZ209) right DC power junction box. (Refer to Cessna Model 700 Maintenance Manual, Chapter 24, DC Power Junction Box Printed Circuit Board (PCB) - Removal/Installation.)
- E. Remove the four screws that attach the left and right PCB enclosure to the DC power junction box.
- F. Lower the left and right PCB enclosures. Make sure to support the PCB enclosures to prevent damage to electrical wires and connectors.
- G. (Refer to Figure 1, Sheets 1 thru 3.) Do the electrical wiring modification per wiring diagrams.
- H. Install the left and right PCB enclosures using the four screws to attach the left and right PCB enclosure to the DC power junction box.
- I. Install the PCB as follows:
  - (1) Install the 7468185-9 Power Distribution PCB Assembly (NZ102) left DC power junction box. (Refer to Cessna Model 700 Maintenance Manual, Chapter 24, DC Power Junction Box Printed Circuit Board (PCB) - Removal/Installation.)
  - (2) Install the 7468185-9 Power Distribution PCB Assembly (NZ202) right DC power junction box. (Refer to Cessna Model 700 Maintenance Manual, Chapter 24, DC Power Junction Box Printed Circuit Board (PCB) - Removal/Installation.)
  - (3) Install the 7468186-5 Auxiliary Power Distribution PCB Assembly (NZ209) right DC power junction box. (Refer to Cessna Model 700 Maintenance Manual, Chapter 24, DC Power Junction Box Printed Circuit Board (PCB) - Removal/Installation.)
- J. Install the left DC power junction box cover as follows:
  - (1) Install the cover on the left DC power junction box.
  - (2) Tighten the fasteners that attach the left DC power junction box cover.
- K. Install left emergency power junction box cover as follows:
  - (1) Install the cover on the left emergency power junction box.
  - (2) Tighten the fasteners that attach the left emergency power junction box cover.
- L. Install the right DC power junction box cover as follows:
  - (1) Install the cover on the right DC power junction box.
  - (2) Tighten the fasteners that attach the right DC power junction box cover.
- M. Do the Operational Check of the APU system as follows:
  - (1) Install the nose landing gear and main landing gear simulator test boxes on the aircraft. (Refer to Cessna Model 700 Maintenance Manual, Chapter 32, Landing Gear - Maintenance Practices.)
    - (a) Make sure the nose landing gear and main landing gear simulator test box switches are in the ON GROUND position.
  - (2) Remove the maintenance warning tags and connect the airplane batteries.

- (3) Push and release the L BATT and the R BATT switches to the ON position.  
**NOTE:** This operational check does not require external electrical power.
- (4) Start the APU. (Refer to the Cessna Model 700 Approved Airplane Flight Manual, Volume 2 (700NP) Revision 1 or later.)
- (5) Start the left and right engines. (Refer to the Cessna Model 700 Approved Airplane Flight Manual, Volume 2 (700NP) Revision 1 or later.)
  - (a) Put the L GEN and R GEN switches to the ON position.
    - 1 Make sure the left and right generators come on-line.
- (6) Stop the APU. (Refer to the Cessna Model 700 Approved Airplane Flight Manual, Volume 2 (700NP) Revision 1 or later.)
- (7) Start the APU. (Refer to the Cessna Model 700 Approved Airplane Flight Manual, Volume 2 (700NP) Revision 1 or later.)
  - (a) During the APU start cycle.
    - 1 Make sure the L and R ELEC switches show (amber) EMER.
    - 2 Make sure the BUS TIE switch shows (amber) CLOSED.
  - (b) After the APU start cycle is complete.
    - 1 Make sure the L and R ELEC switches show (cyan) NORM.
    - 2 Make sure the BUS TIE switch shows (cyan) OPEN.
- (8) Put the nose landing gear and main landing gear test box switches to the IN AIR position.
  - (a) Make sure the left and right engine transition into flight idle.
- (9) Stop the APU. (Refer to the Cessna Model 700 Approved Airplane Flight Manual, Volume 2 (700NP) Revision 1 or later.)
  - (a) Make sure BUS TIE switch shows (cyan) OPEN.
- (10) Start the APU. (Refer to the Cessna Model 700 Approved Airplane Flight Manual, Volume 2 (700NP) Revision 1 or later.)
  - (a) During the APU start cycle.
    - 1 Make sure the L and R ELEC switches show (amber) EMER.
    - 2 Make sure the BUS TIE switch shows (amber) CLOSED.
  - (b) After the APU start cycle is complete.
    - 1 Make sure the L and R ELEC switches show (cyan) NORM.
    - 2 Make sure the BUS TIE switch shows (cyan) OPEN.
- (11) Put the nose landing gear and main landing gear simulator test box switches to the ON GROUND position.
  - (a) Make sure the left and right engine transition into ground idle.
- (12) Stop the APU. (Refer to the Cessna Model 700 Approved Airplane Flight Manual, Volume 2 (700NP) Revision 1 or later.)
- (13) Stop the left and right engines. (Refer to the Cessna Model 700 Approved Airplane Flight Manual, Volume 2 (700NP) Revision 1 or later.)
- (14) Remove the nose landing gear and main landing gear simulator test boxes from the aircraft. (Refer to Cessna Model 700 Maintenance Manual, Chapter 32, Landing Gear - Maintenance Practices.)

3. Make sure the flight crew receives the *Flight Crew Operations Summary*, which shows the operational changes that are a result of the accomplishment of this service bulletin.
4. Make an entry in the airplane logbook that states compliance and method of compliance with this service document.

**NOTE:** Textron Aviation recommends that compliance with all service documents is reported to a maintenance tracking system provider.

- Complete a record of compliance. (Maintenance Transaction Report, Log Book Entry, or other record of compliance.)
- Put a copy of the completed record of compliance in the airplane logbook.
- Send a copy of the completed record of compliance to the maintenance tracking system provider used.

A110034

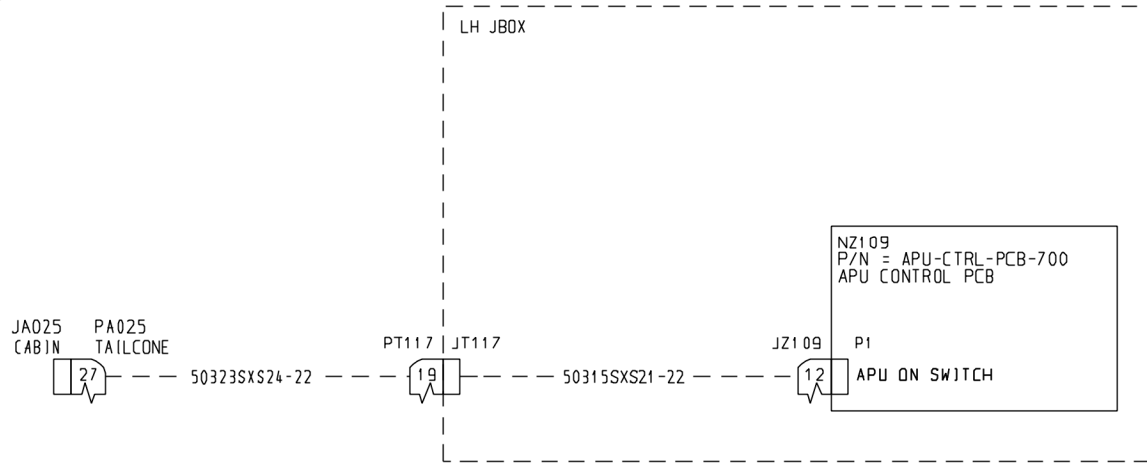

Before Modification

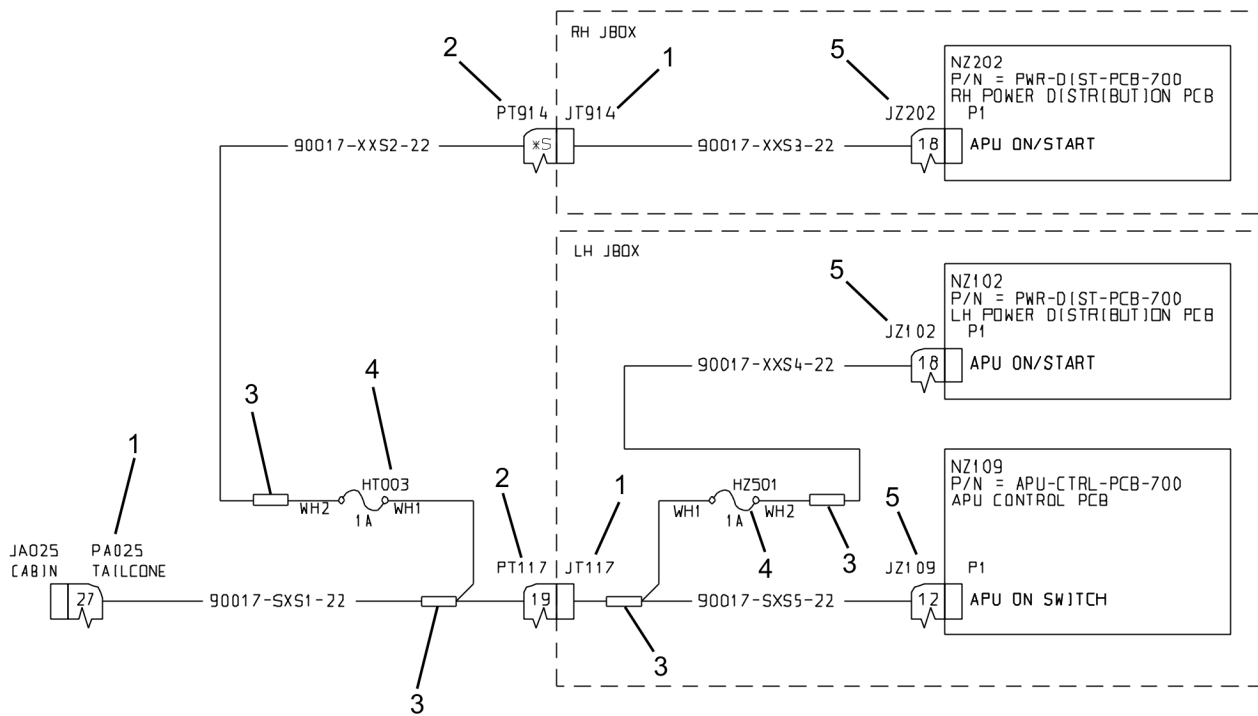

After Modification

| Legend |               |
|--------|---------------|
| 1      | M39029/57-354 |
| 2      | M39029/58-360 |
| 3      | M81824/1-1    |
| 4      | S3491-1       |
| 5      | 3452-6600     |

| Legend |              |
|--------|--------------|
| -----  | Removed Wire |
| —————  | Added Wire   |

8290017

Figure 1. Auxiliary Power Unit (APU) Wiring Modification (Sheet 1)



A110035

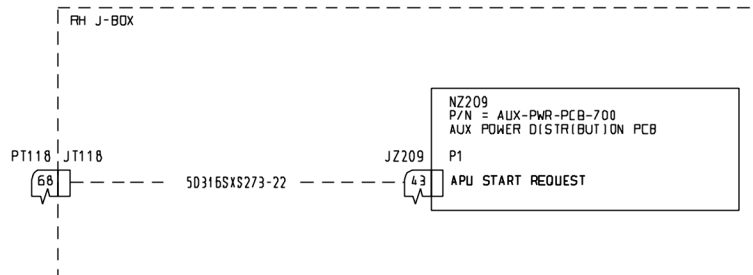
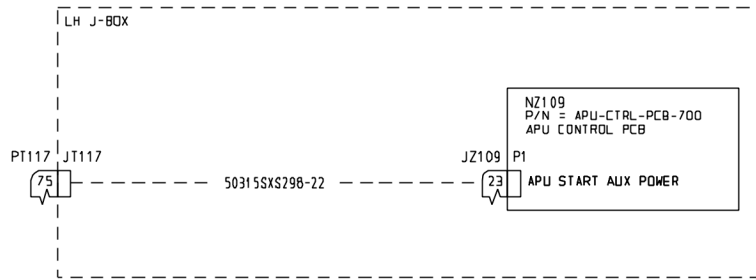

Before Modification

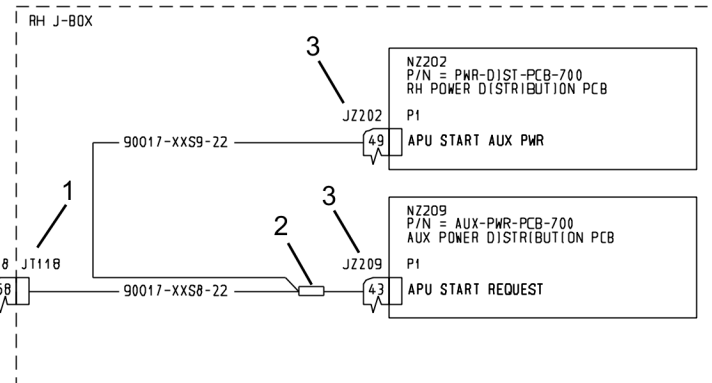
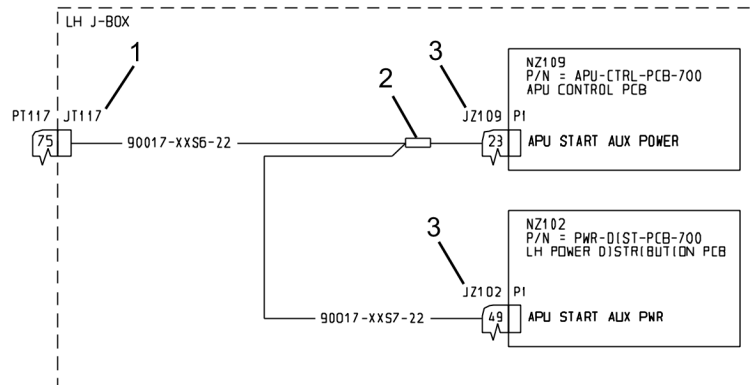

After Modification

| Legend |               |
|--------|---------------|
| 1      | M39029/57-354 |
| 2      | M81824/1-1    |
| 3      | 3452-6600     |

| Legend |              |
|--------|--------------|
| -----  | Removed Wire |
| —————  | Added Wire   |

8290017

Figure 1. Auxiliary Power Unit (APU) Wiring Modification (Sheet 2)

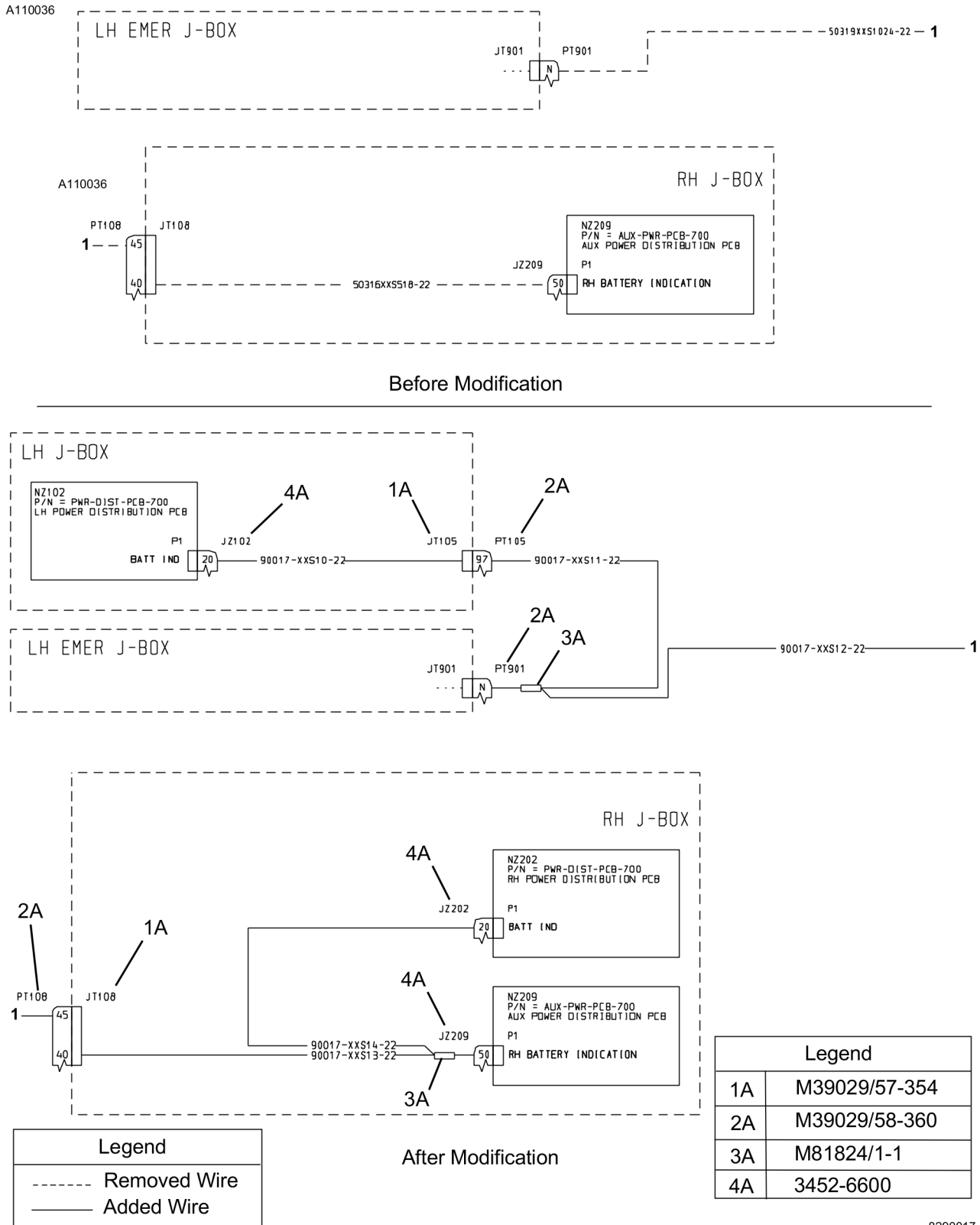

8290017

Figure 1. Auxiliary Power Unit (APU) Wiring Modification (Sheet 3)

**MATERIAL INFORMATION**

Order the kit/parts below to install this modification.

| NEW P/N                     | QTY       | KEY WORD   | OLD P/N | INSTRUCTIONS/<br>DISPOSITION |
|-----------------------------|-----------|--|---------|------------------------------|
| <b>SB700-49-01</b>          | 1         | <b>Kit</b> , consisting of the following parts:      |         |                              |
| 3452-6600                   | 10        | Contact (For JZ connectors in PCB enclosures)        | Install |                              |
| M39029/57-354               | 7         | Contact  | Install |                              |
| M39029/58-360               | 6         | Contact  | Install |                              |
| C489242<br>(M81044/12-22-9) | 5.0 feet  | Jumper Fabrication Wire                              | Install |                              |
| C489242<br>(M81044/12-22-9) | 5.0 feet  | Marked: (90017-4900-SXS1-22) 27PA025 - (SP) 19PT117  | Install |                              |
| C489242<br>(M81044/12-22-9) | 16.0 feet | Marked: (90017-4900-XXS2-22) *SPT914 - (SP) WH2HT003 | Install |                              |
| C489242<br>(M81044/12-22-9) | 3.0 feet  | Marked: (90017-4900-XXS3-22) *SJT914 - 18JZ202       | Install |                              |
| C489242<br>(M81044/12-22-9) | 5.0 feet  | Marked: (90017-4900-XXS4-22) 18JZ102 - (SP) WH2HZ501 | Install |                              |
| C489242<br>(M81044/12-22-9) | 3.0 feet  | Marked: (90017-4900-SXS5-22) 12JZ109 - (SP)19JT117   | Install |                              |
| C489242<br>(M81044/12-22-9) | 3.0 feet  | Marked: (90017-4900-XXS6-22) 75JT117 - (SP) 23JZ109  | Install |                              |
| C489242<br>(M81044/12-22-9) | 3.0 feet  | Marked: (90017-4900-XXS7-22) 49JZ102 - (SP) 23JZ109  | Install |                              |
| C489242<br>(M81044/12-22-9) | 3.0 feet  | Marked: (90017-4900-XXS8-22) 68JT118 - (SP) 43JZ209  | Install |                              |
| C489242<br>(M81044/12-22-9) | 3.0 feet  | Marked: (90017-4900-XXS9-22) 49JZ202 - (SP) 43JZ209  | Install |                              |
| C489242<br>(M81044/12-22-9) | 2.0 feet  | Marked: (90017-2460-XXS10-22) 20JZ102 - 97JT105      | Install |                              |
| C489242<br>(M81044/12-22-9) | 6.0 feet  | Marked: (90017-2460-XXS11-22) 97PT105 - (SP) NPT901  | Install |                              |
| C489242<br>(M81044/12-22-9) | 13.0 feet | Marked: (90017-2460-XXS12-22) 45PT108 - (SP) NPT901  | Install |                              |
| C489242<br>(M81044/12-22-9) | 3.0 feet  | Marked: (90017-2460-XXS13-22) 40JT108 - (SP) 50JZ209 | Install |                              |
| C489242<br>(M81044/12-22-9) | 3.0 feet  | Marked: (90017-2460-XXS14-22) 20JZ202 - (SP) 50JZ209 | Install |                              |
| M81824/1-1                  | 8         | Splice   | Install |                              |

| NEW P/N | QTY | KEY WORD     | OLD P/N | INSTRUCTIONS/<br>DISPOSITION |
|---------|-----|--------------|---------|------------------------------|
| S3491-1 | 2   | Fuse         |         |                              |
| SB      | 1   | Instructions | Install |                              |

Order the parts below to install this modification.

| NEW P/N   | QTY | KEY WORD                                     | OLD P/N   | INSTRUCTIONS/<br>DISPOSITION |
|-----------|-----|--|-----------|------------------------------|
| 7468185-9 | 2   | Power Distribution PCB<br>Assembly           | 7468185-5 | Return to Textron Aviation   |
| 7468186-5 | 1   | Auxiliary Power Distribution<br>PCB Assembly | 7468186-1 | Return to Textron Aviation   |

\* Please contact Textron Aviation Parts Distribution for current cost and availability of parts listed in this service document. Phone at 1-800-835-4000 (Domestic) or 1-316-517-5603 (International). Send email to: [parts@txtav.com](mailto:parts@txtav.com).

Based on availability and lead times, parts may require advanced scheduling.

In cases where the required part(s) are approved as exchange, order the exchange part and, upon completion, expedite the return of the removed part to avoid return penalties. Contact the Textron Aviation Parts Distribution Sales Desk for availability of exchange parts.

## FLIGHT CREW OPERATIONS SUMMARY

SB700-49-01 - *Modification of the Auxiliary Power Unit (APU) Starting System*

This summary provides additional information for the flight crew regarding operational changes as a result of accomplishment of this service bulletin. Please remove this summary from the service bulletin and give it to the flight crew. This summary is *informational only* and does not supersede any information in the FAA-approved airplane flight manual.

- This service bulletin modifies the power distribution logic to automatically isolate the APU starter from the engine-driven generators during an APU start.
- For normal operations with both generators online, the APU can be started at or below FL310 within the operational speed envelope of the airplane and there is no longer a restriction on engine N2. Previously, APU starts were limited to at or below 15,000 feet and a minimum of 72% N2.
- For abnormal operations when there is only one generator online, it is possible to exceed horsepower extraction limits of the engine while the batteries are recharging. Due to differences in allowable horsepower extraction between normal and abnormal operations, APU starts with a single generator online are restricted to at or below 15,000 feet and a maximum of 89% N2. The AFM (700EAP-02) lists these restrictions for procedures in which there will only be a single generator online.



**TITLE**

AUXILIARY POWER - MODIFICATION OF THE AUXILIARY POWER UNIT (APU) STARTING SYSTEM

**TO:**

Cessna Model 700 Aircraft Owner

**REASON**

To change the APU start sequence up to thirty-one thousand feet with both engine driven generators ON and without engine N2 speed limitations..

**COMPLIANCE**

DISCRETIONARY. This service document can be accomplished at the discretion of the owner.

**LABOR HOURS**

| WORK PHASE   | LABOR-HOURS |
|--------------|-------------|
| Modification | 65.0        |

**MATERIAL AVAILABILITY**

The parts below are required to complete this service document.

| PART NUMBER | AVAILABILITY | COST |
|-------------|--------------|------|
| SB700-49-01 | *            | *    |
| 7468185-9   | *            | *    |
| 7468186-5   | *            | *    |

The existing 7468185-5 and 7468186-1 may be returned to Textron Aviation Parts Distribution, Warranty Administration, 285 South Greenwich Road, Bldg B89, Docks 1-4, Wichita, KS 67206, USA, and exchanged for an upgraded unit. Due to limited availability, advance scheduling is required, please expedite the return of the removed part.

\* Please contact Textron Aviation Parts Distribution for current cost and availability of parts listed in this service document. Phone at 1-800-835-4000 (Domestic) or 1-316-517-5603 (International). Send email to: parts@txtav.com.

Based on availability and lead times, parts may require advanced scheduling.

In cases where the required part(s) are approved as exchange, order the exchange part and, upon completion, expedite the return of the removed part to avoid return penalties. Contact the Textron Aviation Parts Distribution Sales Desk for availability of exchange parts.

**WARRANTY**

Eligible airplanes exhibiting conditions described in this service document may demonstrate improved operation by incorporation of the work described herein. This service document is to be accomplished at the *discretion* of the owner. Eligible airplanes may qualify for parts and labor coverage to the extent noted in the *Labor Hours* and *Material Availability* sections of this document.

**Eligibility:** Airplanes identified within the serial number effectivity of this service document must have active Airframe warranty coverage on the original issue date of this document and the coverage must be active on the day the work is accomplished.

**Parts Coverage:** Textron Aviation-owned and Textron Aviation-authorized Service Facilities, operators, or other maintenance facilities may submit a claim for the parts required to accomplish this service document as defined in the *Material Availability* section of this document.

**Labor Coverage:** Textron Aviation-owned and Textron Aviation-authorized Service Facilities rated to perform maintenance on the specific model of Cessna Aircraft may submit a claim for the labor necessary to accomplish this service document as defined in the *Labor Hours* section of this document.

**Credit Application:** After this service document has been accomplished, a claim must be submitted to Textron Aviation within 30 days of the service document completion. Claims for compliance of this service document are to be filed as a W4 type claim.

Please submit your claim form online at [ww2.txtav.com/Parts](http://ww2.txtav.com/Parts) or email the completed Textron Aviation Claim Form to [warranty@txtav.com](mailto:warranty@txtav.com). If submitted on-line a Return Authorization will be provided. If a paper claim is submitted your claim will be entered into the system and a Return Authorization will be sent to you.

The Return Authorization must accompany any required return parts (see *Material Availability*), to the point of purchase.

Parts to be returned to Textron Aviation Parts Distribution should be forwarded to:

Textron Aviation Parts Distribution  
Warranty Administration  
285 South Greenwich Road  
Bldg B89, Docks 1-4  
Wichita, KS 67206  
USA

**Expiration:** March 1, 2023 (after this date the owner/operator assumes the responsibility for compliance costs)

Textron Aviation reserves the right to void continued airplane warranty coverage for the parts affected by this service document until the service document is accomplished.

**NOTE:** As a convenience, service documents are now available online to all our customers through a simple, free-of-charge registration process. If you would like to sign up, please visit the Customer Access link at [www.txtavsupport.com](http://www.txtavsupport.com) to register.