

Revision Transmittal

June 11, 2015

TO: Cessna Distributors and Single Engine Authorized Service Facilities and CPC's

SUBJECT: Single Engine Service Bulletin SEB07-5 Revision 6, Pilot and Copilot Secondary Seat Stop Installation.

REASON FOR REVISION

To extend the credit expiration date.
Miscellaneous changes as required.

REQUIRED ACTION

Please replace any copy of SEB07-5 Revision 5 with the attached copy of SEB07-5 Revision 6 which is printed in its entirety.

NOTE: Compliance with Revision 6 is not required if in compliance with the Original Issue or a previous revision. However, if you have not already done so, you must remove and destroy the Instructions for Continued Airworthiness Attachment that is stored in the Technical Library CD-ROM or Maintenance Manual for your airplane and replace it with the Instructions for Continued Airworthiness Revision A that is attached to this service bulletin.

LOG OF EFFECTIVE PAGES

Page No.	Date	Page No.	Date
1	June 11, 2015	12	June 11, 2015
2	June 11, 2015	13	June 11, 2015
3	June 11, 2015	14	June 11, 2015
4	June 11, 2015	15	June 11, 2015
5	June 11, 2015	16	June 11, 2015
6	June 11, 2015	17	June 11, 2015
7	June 11, 2015	18	June 11, 2015
8	June 11, 2015	19	June 11, 2015
9	June 11, 2015	20	June 11, 2015
10	June 11, 2015	21	June 11, 2015
11	June 11, 2015	22	June 11, 2015

* * * * *

Page 1 of 1

To obtain satisfactory results, procedures specified in this publication must be accomplished in accordance with accepted methods and prevailing government regulations. Cessna Aircraft Company cannot be responsible for the quality of work performed in accomplishing the requirements of this publication.

Service Bulletin

June 11, 2015

SEB07-5
Revision 6

TITLE

PILOT AND COPILOT SECONDARY SEAT STOP INSTALLATION

EFFECTIVITY

<u>Model</u>	<u>Year</u>	<u>Serial Numbers</u>
170	1948	18000 thru 18729
170A	1949 thru 1951	18730 thru 19400
170A	1949 thru 1951	19402 thru 20266
170B	1952 thru 1956	20267 thru 20999
170B	1952 thru 1956	25000 thru 27169
170B		609, 19401
172	1956 thru 1959	28000 thru 29999
172	1956 thru 1959	36000 thru 36999
172	1956 thru 1959	46001 thru 46754
172		610, 612, 615
172A	1960	46755 thru 47746
172A		622, 625
172B	1961	17247747 thru 17248734
172B		630
172C	1962	17248735 thru 17249544
172D	1963	17249545 thru 17250572
172E	1964	17250573 thru 17251822
172E		639
172F	1965	17251823 thru 17253392
172G	1966	17253393 thru 17254892
172H	1967	17254893 thru 17256492
172H	1967	17256494 thru 17256512

Original Issue: May 14, 2007
Revision 1: December 17, 2007
Revision 2: June 15, 2010
Revision 3: December 15, 2011
Revision 4: March 15, 2012
Revision 5: November 11, 2013

Page 1 of 22

To obtain satisfactory results, procedures specified in this publication must be accomplished in accordance with accepted methods and prevailing government regulations. Cessna Aircraft Company cannot be responsible for the quality of work performed in accomplishing the requirements of this publication.

172H		638
172I	1968	17256513 thru 17257161
172J		660
172K	1969	17257162 thru 17258486
172K	1970	17258487 thru 17259223
172L	1971	17259224 thru 17259903
172L	1972	17259904 thru 17260758
172M	1973	17260759 thru 17261444
172M	1973	17261446 thru 17261577
172M	1973	17261579 thru 17261898
172M		17256493
172M	1974	17261899 thru 17263458
172M	1975	17263459 thru 17265684
172M	1976	17265685 thru 17267584
172N	1977	17267585 thru 17269309
172N		17261445
172N	1978	17269310 thru 17270049
172N	1978	17270051 thru 17271034
172N		17261578
172N	1979	17271035 thru 17272884
172N	1980	17272885 thru 17274009
172N		17270050
172P	1981	17274010 thru 17275034
172P	1982	17275035 thru 17275759
172P	1983	17275760 thru 17276079
172P	1984	17276080 thru 17276259
172P	1985	17276260 thru 17276516
172P	1986	17276517 thru 17276654
172Q	1983	17275869
172Q	1983	17275927 thru 17275934
172Q	1983	17275952, 17275959, 17275960
172Q	1983	17275962, 17275964, 17275965
172Q	1983	17275967, 17275968, 17275969
172Q	1983	17275971, 17275992, 17275999
172Q	1983	17276002, 17276005, 17276029
172Q	1983	17276032, 17276042, 17276045
172Q	1983	17276051, 17276052, 17276054
172Q	1984	17276101, 17276109, 17276140
172Q	1984	17276147, 17276188, 17276211
175	1958 thru 1959	55001 thru 56238
175		28700A, 626, 640

175A	1960	56239 thru 56777
175A		619
175B	1961	17556778 thru 17557002
175C	1962	17557003 thru 17557119
P172D	1963	P17257120 thru P17257188
R172E (T41)	1967 thru 1968	R172-0001 thru R172-0335
R172F (T41)	1969	R172-0336 thru R172-0409
R172G (T41)	1969 thru 1970	R1720410 thru R1720444
R172H (T41)	1971	R1720445 thru R1720494
R172H (T41)	1972	R1720495 thru R1720546
R172H (T41)	1973 thru 1976	R1720547 thru R1720620
R172J	1974	P17257189
R172K	1977	R1722000 thru R1722724
R172K	1978	R1722725 thru R1722929
R172K	1979	R1722930 thru R1723199
R172K		680
R172K	1980	R1723200 thru R1723399
R172K	1981	R1723400 thru R1723454
172RG	1980	172RG0001 thru 172RG0570
172RG	1981	172RG0571 thru 172RG0890
172RG		691
172RG	1982	172RG0891 thru 172RG1099
172RG	1983	172RG1100 thru 172RG1144
172RG	1984	172RG1145 thru 172RG1177
172RG	1985	172RG1178 thru 172RG1191
177	1968	17700001
177	1968	17700003 thru 17701164
177		661
177A	1969	17701165 thru 17701370
177B	1970	17701371 thru 17701471
177B	1970	17701473 thru 17701530
177B	1971	17701531 thru 17701633
177B		17700002
177B	1972	17701634 thru 17701773
177B	1973	17701774 thru 17701973
177B	1974	17701974 thru 17702123
177B	1975	17702124 thru 17702313
177B		17701472
177B	1976	17702314 thru 17702522
177B	1977	17702523 thru 17702672
177B	1978	17702673 thru 17702752

177RG	1971	177RG0001 thru 177RG0212
177RG	1972	177RG0213 thru 177RG0282
177RG	1973	177RG0283 thru 177RG0418
177RG	1973	177RG0420 thru 177RG0432
177RG	1974	177RG0433 thru 177RG0592
177RG	1975	177RG0593 thru 177RG0787
177RG	1976	177RG0788 thru 177RG1051
177RG	1977	177RG1052 thru 177RG1266
177RG	1978	177RG1267 thru 177RG1366
177RG		177RG0419
180	1953 thru 1956	30000 thru 32661
180		604, 614
180A	1957	32662 thru 32999
180A	1957 thru 1958	50001 thru 50355
180B	1959	50356 thru 50661
180C	1960	50662 thru 50911
180C		624
180D	1961	18050912 thru 18051063
180E	1962	18051064 thru 18051183
180F	1963	18051184 thru 18051312
180G	1964	18051313 thru 18051445
180H	1965 thru 1972	18051446 thru 18052284
180H		645
180J	1973 thru 1976	18052285 thru 18052489
180J	1973 thru 1976	18052491 thru 18052770
180K	1977	18052771 thru 18052905
180K	1978	18052906 thru 18053000
180K	1979	18053001 thru 18053115
180K		18052490
180K	1980	18053116 thru 18053167
180K	1981	18053168 thru 18053203
182	1956	33000 thru 33842
182		613
182A	1957	33843 thru 34753
182A	1958	34755 thru 34999
182A	1958	51001 thru 51556
182B	1959	51557 thru 51622
182B	1959	51624 thru 52358
182B		34754
182C	1960	52359 thru 53007
182C		631

182D	1961	18253008 thru 18253598
182D	1961	51623
182E	1962	18253599 thru 18254423
182F	1963	18254424 thru 18255058
182G	1964	18255059 thru 18255844
182H	1965	18255846 thru 18256684
182H		634
182J	1966	18256685 thru 18257625
182K	1967	18257626 thru 18257698
182K	1967	18257700 thru 18258505
182K	1967	18255845
182L	1968	18258506 thru 18259305
182M		662
182M	1969	18259306 thru 18260055
182M		18257699
182N	1970	18260056 thru 18260445
182N	1971	18260446 thru 18260825
182P	1972	18260826 thru 18261425
182P	1973	18261426 thru 18262465
182P	1974	18262466 thru 18263475
182P	1975	18263476 thru 18263478
182P	1975	18263480 thru 18264295
182P		675
182P	1976	18264296 thru 18265175
182Q	1977	18265176 thru 18265965
182Q	1978	18265966 thru 18266590
182Q		18263479
182Q	1979	18266591 thru 18267300
182Q	1980	18267301
182Q	1980	18267303 thru 18267715
182R/T182	1981	18267716 thru 18268055
182R/T182		18267302
182R/T182	1982	18268056 thru 18268293
182R/T182	1983	18268294 thru 18268368
182R/T182	1984	18268369 thru 18268434
182R/T182	1985	18268435 thru 18268541
182R	1986	18268542 thru 18268586
R182		683
R182	1978	R18200002 thru R18200583
R182/TR182	1979	R18200584 thru R18201313
R182/TR182		R18200001

R182/TR182	1980	R18201314
R182/TR182	1980	R18201316 thru R18201628
R182/TR182	1981	R18201629 thru R18201798
R182/TR182	1982	R18201799 thru R18201928
R182/TR182	1983	R18201929 thru R18201973
R182/TR182	1984	R18201974 thru R18201999
R182/TR182	1985	R18202000 thru R18202031
R182/TR182		R18201315
R182/TR182	1986	R18202032 thru R18202039
185	1961	185-0001 thru 185-0237
185		632
185A	1962	185-0238 thru 185-0512
185B	1963	185-0513 thru 185-0653
185C	1964	185-0654 thru 185-0776
185D	1965	185-0777 thru 185-0967
185E	1966	185-0968 thru 185-1149
A185E	1966	185-0968 thru 185-1149
A185E	1967	185-1150 thru 185-1300
A185E	1968	185-1301 thru 185-1447
A185E	1969	185-1448 thru 185-1599
A185E	1970/1971	18501600 thru 18501934
A185E	1972	18501935 thru 18502090
A185F	1973	18502091 thru 18502299
A185F	1973	18502301 thru 18502310
A185F		652
A185F	1974	18502311 thru 18502565
A185F	1975	18502566 thru 18502838
A185F	1976	18502839 thru 18503153
A185F	1977	18503154 thru 18503458
A185F	1978	18503459 thru 18503683
A185F	1979	18503684 thru 18503938
A185F		18502300
A185F	1980	18503939 thru 18504138
A185F	1981	18504139 thru 18504328
A185F	1982	18504329 thru 18504394
A185F	1983	18504395 thru 18504415
A185F	1984	18504416 thru 18504424
A185F	1985	18504425 thru 18504448
190	1948 thru 1953	7004 thru 7999
190	1948 thru 1953	16000 thru 16183
195	1948 thru 1953	7004 thru 7999

195	1948 thru 1953	16000 thru 16183
195A	1948 thru 1953	7004 thru 7999
195A	1948 thru 1953	16000 thru 16183
195B	1948 thru 1953	7004 thru 7999
195B	1948 thru 1953	16000 thru 16183
210-5 (205)	1963	205-0001 thru 205-0480
210-5 (205)		641, 648
210-5 (205A)	1964	205-0481 thru 205-0577
206	1964	206-0001 thru 206-0275
U206	1965	U206-0276 thru U206-0437
U206A	1966	U206-0438 thru U206-0656
TU206A	1966	U206-0487 thru U206-0656
U206B/TU206B	1967	U206-0657 thru U206-0914
U206C/TU206C	1968	U206-0915 thru U206-1234
U206D/TU206D	1969	U206-1235 thru U206-1444
U206D/TU206D	1970	U20601445 thru U20601587
U206E/TU206E	1971	U20601588 thru U20601700
U206F/TU206F	1972	U20601701 thru U20601874
U206F/TU206F	1973	U20601875 thru U20602199
U206F/TU206F	1974	U20602200 thru U20602579
U206F/TU206F	1975	U20602580 thru U20602588
U206F/TU206F	1975	U20602590 thru U20603020
U206F/TU206F	1976	U20603021 thru U20603521
U206G/TU206G	1977	U20603522 thru U20604074
U206G/TU206G		676
U206G/TU206G	1978	U20604075 thru U20604649
U206G/TU206G	1979	U20604650 thru U20605309
U206G/TU206G		U20602589
U206G/TU206G	1980	U20605310 thru U20605919
U206G/TU206G	1981	U20605920 thru U20606439
U206G/TU206G	1982	U20606440 thru U20606699
U206G/TU206G	1983	U20606700 thru U20606788
U206G/TU206G	1984	U20606789 thru U20606846
U206G/TU206G	1985	U20606847 thru U20606920
U206G/TU206G	1986	U20606921 thru U20607020
P206	1965	P206-0002 thru P206-0160
P206A	1966	P206-0161 thru P206-0306
TP206A	1966	P206-0161 thru P206-0306
P206B/TP206B	1967	P206-0307 thru P206-0419
P206C/TP206C	1968	P206-0420 thru P206-0519
P206D/TP206D	1969	P206-0520 thru P206-0603

P206E/TP206E	1970	P20600604 thru P20600647
P206E/TP206E		P206-0001
207/T207	1969	20700001 thru 20700148
207/T207	1970	20700149 thru 20700190
207/T207	1971	20700191 thru 20700205
207/T207	1972	20700206 thru 20700215
207/T207	1973	20700216 thru 20700227
207/T207	1974	20700228 thru 20700267
207/T207	1975	20700268 thru 20700314
207/T207	1976	20700315 thru 20700362
207A/T207A	1977	20700363 thru 20700414
207A/T207A	1978	20700415 thru 20700482
207A/T207A	1979	20700483 thru 20700562
207A/T207A	1980	20700563 thru 20700654
207A/T207A	1981	20700655 thru 20700729
207A/T207A	1982	20700730 thru 20700762
207A/T207A	1983	20700763 thru 20700767
207A/T207A	1984	20700768 thru 20700788
210	1960	57001 thru 57575
210		618
210A	1961	21057576 thru 21057840
210A		616
210B	1962	21057841 thru 21058085
210C	1963	21058086 thru 21058139
210C	1963	21058141 thru 21058220
210D	1964	21058221 thru 21058510
210E	1965	21058511 thru 21058715
210F	1966	21058716 thru 21058818
210G	1967	21058819 thru 21058936
210H	1968	21058937 thru 21059061
210J	1969	21059062 thru 21059199
210K/T210K	1970	21059200 thru 21059351
210K/T210K	1971	21059352 thru 21059502
210L/T210L	1972	21059503 thru 21059719
210L/T210L	1973	21059720 thru 21060089
210L/T210L	1974	21060090 thru 21060539
210L/T210L	1975	21060540 thru 21061039
210L/T210L	1976	21061040 thru 21061041
210L/T210L	1976	21061043 thru 21061573
210M/T210M	1977	21061574 thru 21062273
210M/T210M	1978	21062274 thru 21062954

210M/T210M	1978	21061042
210N/T210N	1979	21062955 thru 21063640
210N/T210N	1980	21063641 thru 21064135
210N/T210N	1981	21064136 thru 21064535
210N/T210N	1982	21064536 thru 21064772
210N/T210N	1983	21064773 thru 21064822
210N/T210N	1984	21064823 thru 21064897
210R/T210R	1985	21064898 thru 21064949
210R/T210R	1986	21064950 thru 21065009
T210F	1966	T210-0001 thru T210-0197
T210G	1967	T210-0198 thru T210-0307
T210H	1968	T210-0308 thru T210-0392
T210J	1969	T210-0393 thru T210-0454
T210J		21058140
P210N	1978	P21000001 thru P21000150
P210N	1979	P21000151 thru P21000385
P210N	1980	P21000386 thru P21000590
P210N	1981	P21000591 thru P21000760
P210N	1982	P21000761 thru P21000811
P210N	1983	P21000812 thru P21000834
P210R	1985	P21000835 thru P21000866
P210R	1986	P21000867 thru P21000874
A182J	1966	A182-0001 thru A182-0056
A182K	1967	A182-0057 thru A182-0096
A182L	1968	A182-0097 thru A182-0116
A182N	1972	A182-0117 thru A182-0136
A182N	1974	A182-0137 thru A182-0146
A182N	1976	A182-0147 thru A182-0148
FP172	1963	FP172-0001 thru FP172-0003
F172D	1963	F172-0001 thru F172-0018
F172E	1964	F172-0019 thru F172-0085
F172F	1965	F172-0086 thru F172-0179
F172G	1966	F172-0180 thru F172-0319
F172H	1967	F172-0320 thru F172-0431
F172H	1967	F172-0436 thru F172-0442
F172H	1967	F172-0444 thru F172-0446
F172H	1968	F172-0432 thru F172-0435
F172H	1968	F172-0443
F172H	1968	F172-0447 thru F172-0559
F172H	1969	F172-0560 thru F172-0654
F172H	1970	F17200655 thru F17200754

F172K	1971	F17200755 thru F17200804
F172L	1972	F17200805 thru F17200904
F172M	1973	F17200905 thru F17201034
F172M	1974	F17201035 thru F17201234
F172M	1975	F17201235 thru F17201384
F172M	1976	F17201385 thru F17201514
F172N	1977	F17201515 thru F17201639
F172N	1978	F17201640 thru F17201749
F172N	1979	F17201750 thru F17201909
F172N	1980	F17201910 thru F17202039
F172P	1981	F17202040 thru F17202134
F172P	1982	F17202135 thru F17202194
F172P	1983	F17202195 thru F17202216
F172P	1984	F17202217 thru F17202233
F172P	1985	F17202234 thru F17202238
F172P	1986	F17202239 thru F17202254
FR172E	1968	FR17200001 thru FR17200060
FR172F	1969	FR17200061 thru FR17200145
FR172G	1970	FR17200146 thru FR17200225
FR172H	1971	FR17200226 thru FR17200275
FR172H	1972	FR17200276 thru FR17200350
FR172J	1973	FR17200351 thru FR17200440
FR172J	1974	FR17200441 thru FR17200530
FR172J	1975	FR17200531 thru FR17200559
FR172J	1976	FR17200560 thru FR17200590
FR172K	1977	FR17200591 thru FR17200620
FR172K	1978	FR17200621 thru FR17200630
FR172K	1979	FR17200631 thru FR17200655
FR172K	1980	FR17200656 thru FR17200665
FR172K	1981	FR17200666 thru FR17200675
F177RG	1971	F177RG0001 thru F177RG0042
F177RG	1972	F177RG0043 thru F177RG0062
F177RG	1973	F177RG0063 thru F177RG0092
F177RG	1974	F177RG0093 thru F177RG0122
F177RG	1975	F177RG0123 thru F177RG0138
F177RG	1976	F177RG0139 thru F177RG0160
F177RG	1977	F177RG0161 thru F177RG0177
F182P	1976	F18200001 thru F18200025
F182Q	1977	F18200026 thru F18200064
F182Q	1978	F18200065 thru F18200094
F182Q	1979	F18200095 thru F18200129

F182Q	1980	F18200130 thru F18200169
FR182	1978	FR18200001 thru FR18200020
FR182	1979	FR18200021 thru FR18200045
FR182	1980	FR18200046 thru FR18200070

PURPOSE

To provide a modification for installing a new design secondary seat stop for the pilot and copilot seats.

The Secondary Seat Stop is an additional device installed on the pilot or copilot seat that assists in preventing uncommanded rearward movement of the seat. It is designed to assist in providing an additional margin of safety by limiting the aft travel of the seat should the primary seat latch pin(s) not be properly engaged in the seat rail/track. In certain instances, seat slippage could result in some pilots not being able to reach all the controls and/or subsequently losing control of the airplane. The functionality of the Secondary Seat Stop should be completely transparent to the operator. If operation of the seat stop is not transparent the airplane requires maintenance to correct the malfunction of the seat stop mechanism.

COMPLIANCE

Mandatory: Pilot seat secondary stop installation shall be accomplished within the next 200 hours of operation or 12 months, whichever occurs first.

Recommended: Copilot seat secondary stop installation should be accomplished within the next 200 hours of operation or 12 months, whichever occurs first.

NOTE: This Service Bulletin supersedes Service Bulletin SEB89-2: Pilot Seat Secondary Stop Installation (all revisions).

NOTE: Compliance with Revision 6 is not required if in compliance with the Original Issue or a previous revision. However, if you have not already done so, you must remove and destroy the Instructions for Continued Airworthiness Attachment that is stored in the Technical Library CD-ROM or Maintenance Manual for your airplane and replace it with the Instructions for Continued Airworthiness Revision A that is attached to this service bulletin.

APPROVAL

Cessna received FAA approval for the technical data in this publication that changes the airplane type design.

Cessna received EASA approval for the technical data in this publication that changes the airplane type design.

MAN-HOURS

NOTE: The man-hours listed below are provided as a guide for scheduling and planning purposes only.

The man-hours listed below are based on the work being accomplished during a scheduled 100 hour/annual type inspection.

SK195-11A: Pilot Secondary Seat Stop Installation

6.7 man-hours per airplane

SK195-12A: Copilot Secondary Seat Stop Installation

Approximately 6.2 man-hours per airplane

SK210-174B: Pilot Secondary Seat Stop Installation

Installation "A": 3.5 man-hours per airplane

Installation "B": 3.4 man-hours per airplane

Installation "C": 1.5 man-hours per airplane

Installation "D": 2.9 man-hours per airplane

Installation "E": 2.2 man-hours per airplane

Installation "F": 2.0 man-hours per airplane

Installation "G": 2.4 man-hours per airplane

Installation "H": 2.4 man-hours per airplane

Installation "J": 5.4 man-hours per airplane

Installation "K": 3.6 man-hours per airplane

Installation "L": 2.8 man-hours per airplane

Installation "M": 2.6 man-hours per airplane

SK210-175A: Copilot Secondary Seat Stop Installation

Installation "A": Approximately 3.0 man-hours per airplane

Installation "B": Approximately 2.9 man-hours per airplane

Installation "C": Approximately 1.0 man-hour per airplane

Installation "D": Approximately 2.4 man-hours per airplane

Installation "E": Approximately 1.7 man-hours per airplane

Installation "F": Approximately 1.5 man-hours per airplane

Installation "G": Approximately 1.9 man-hours per airplane

Installation "H": Approximately 1.9 man-hours per airplane

Installation "J": Approximately 4.9 man-hours per airplane

Installation "K": Approximately 3.1 man-hours per airplane

Installation "L": 2.8 man-hours per airplane

Installation "M": 2.6 man-hours per airplane

MATERIAL

The parts below are available from Cessna Service Parts and Programs through an appropriate Cessna Authorized Service Facility.

NOTE: The airplane serial number must be provided when ordering the seat stop service kits.

<u>Part Number</u>	<u>Description</u>	<u>Qty/Airplane</u>
SK195-11A	Pilot Secondary Seat Stop Installation Kit (Models 190/195)	1
SK195-12A	Copilot Secondary Seat Stop Installation Kit (Models 190/195)	1
SK210-174B	Pilot Secondary Seat Stop Installation Kit (Models 170-P210 except Models 190/195)	1
SK210-175A	Copilot Secondary Seat Stop Installation Kit (Models 170-P210 except Models 190/195)	1
U000787S	EC1300LP Adhesive (1 Pint)	(as required)

ACCOMPLISHMENT INSTRUCTIONS

Service Kit installation instructions are included in the following Service Kits when the kits are shipped from Cessna Service Parts and Programs.

SK195-11A and SK210-174B Pilot Secondary Seat Stop Installation; SK195-12A and SK210-175A: Copilot Secondary Seat Stop Installation.

For your convenience the typical installation of the secondary seat stop installation configurations are shown in Figure 1.

Store the attachment that follows - Airplanes Incorporating: SK210-174, SK210-175, SK195-11, SK195-12, SK337-75, or SK337-76 (Any of these SKs at any Revision level) Instructions for Continued Airworthiness, Revision A - with the airplane maintenance manual.

**AIRPLANES INCORPORATING:
SK210-174, SK210-175, SK195-11, SK195-12, SK337-75, or SK337-76
(Any of these SKs at any Revision level)**

**- INSTRUCTIONS FOR CONTINUED AIRWORTHINESS -
- Revision A -**

Cessna Aircraft Company
P.O. Box 7704
Wichita, Kansas 67277

Model Numbers
170 / 172 / 175 / 177 / 177RG
180 / (T)182 / R182 / TR182 / 185
190 / 195
(T)206 / (T)207 / (T)210 / P210
T303 / 336 / (T)337 / P337

1. Introduction

- A. The purpose of this Service Bulletin Attachment is to provide the maintenance technician with the information necessary to ensure the correct functionality and operation of the Secondary Seat Stop installed by accomplishment of either SK210-174, SK210-175, SK195-11, SK195-12, SK337-75, or SK337-76 on the applicable Cessna Models.
- B. This document supplements the applicable Model Maintenance Manual or Service Manual until the next revision to the Manual is accomplished.
- C. When this information is incorporated into the applicable Model Maintenance Manual, the Maintenance Manual shall take precedence over this document.

NOTE: This document must be placed with the aircraft operator's Technical Library CD-ROM or Maintenance Manual and incorporated into the operator's scheduled maintenance program.

2. Description and Operation

A. Description

- The Secondary Seat Stop is an additional device installed on the pilot or copilot seat that assists in preventing uncommanded rearward movement of the seat. It is designed to assist in providing an additional margin of safety by limiting the aft travel of the seat should the primary seat latch pin(s) not be properly engaged in the seat rail/track. In certain instances, seat slippage could result in some pilots not being able to reach all the controls and/or subsequently losing control of the airplane. The functionality of the Secondary Seat Stop should be completely transparent to the operator. If operation of the seat stop is not transparent the airplane requires maintenance to correct the malfunction of the seat stop mechanism.

B. Operation

- (1) The control cable of the Secondary Seat Stop is connected to the Seat Latch Pin or Seat Adjustment Handle near the Latch Pin. When properly rigged, the Secondary Seat Stop should be engaged, preventing aft movement of the seat when the Latch Pin is in the seat rail/track hole or resting atop the rail/track.
- (2) When the Latch Pin is engaged in the seat rail hole or is raised to no more than 0.05 inch above the seat rail/track using the Seat Adjustment Handle, the Secondary Seat Stop should engage, thereby permitting no further aft movement of the seat.

C. System Components

- (1) One of the following Cessna Service Kits at any revision level:
 - SK210-174
 - SK210-175
 - SK195-11
 - SK195-12
 - SK337-75
 - SK337-76

3. Installation and Rigging

- Installation and rigging of the Secondary Seat Stop are to be done in accordance with the applicable Service Kit (SK).

4. Required Maintenance

A. Inspection/Test

- (1) Stand outside the airplane with the door open.
- (2) Check to see if the latch pin is engaged in a hole in the rail/track.
 - (a) If it is, proceed to step (3).
 - (b) If it is not, adjust the seat to put a pin in a hole in the seat rail/track.
- (3) Grasp the belt about mid-way between its attachment to the floor and the seat base. Attempt to pull more belt material from the reel.
 - (a) If you can pull more of the belt from the reel, it must be re-rigged. Adjust the cable in accordance with the applicable SK rigging instructions.
 - (b) If you are unable to pull more of the belt from the reel, proceed to step (4).
- (4) Lift the seat adjustment handle and reposition the seat so that the latch pin rests atop the rail/track, not in a hole. Attempt to pull more belt material from the reel.
 - (a) If you can pull more of the belt from the reel, it must be re-rigged. Adjust the cable in accordance with the applicable SK rigging instructions.
 - (b) If you are unable to pull more of the belt from the reel, proceed to step (5).
- (5) Lift the seat adjustment handle and place a 0.05" thick feeler gauge on top of the rail and then lower the seat latch pin onto it. Attempt to pull more belt material from the reel.
 - (a) If you can pull more of the belt from the reel, it must be re-rigged. Adjust the cable in accordance with the applicable SK rigging instructions.
 - (b) If you are unable to pull more of the belt from the reel, proceed to step (6).
- (6) Lift the seat adjustment handle and place a 0.10" thick feeler gauge on top of the rail and then lower the seat latch pin onto it. Attempt to pull more belt material from the reel.
 - (a) If you are unable to pull more of the belt from the reel, it must be re-rigged. Adjust the cable in accordance with the applicable SK rigging instructions.
 - (b) If you can pull more of the belt from the reel, proceed to step (7).
- (7) Sit in the seat and repeat steps (2) thru (6) while seated. There should be no different functionality than when standing outside the airplane. If there is, adjust the reel and cable in accordance with the applicable SK installation and rigging instructions.

B. Inspection Interval

- (1) At each 100 Hour or Annual Inspection, whichever comes first, perform Steps 4, A, (1) thru (7), above.
- (2) Perform Steps 4, A, (1) thru (7) any time the operator notes intermittent or poor functioning of the Secondary Seat Stop or is unable to move the seat aft when commanded.

C. Troubleshooting

- (1) If the Secondary Seat Stop requires repeated rigging.
 - (a) Inspect the primary seat latch system for condition and wear.
 - (b) Replace worn or damaged parts.
 - (c) Re-rig the secondary seat stop in accordance with the applicable SK.

- (2) If insufficient handle movement is available to “release” the secondary seat stop.
 - (a) Inspect the primary seat latch system for condition and wear.
 - (b) Replace worn or damaged parts.
 - (c) Re-rig the secondary seat stop in accordance with the applicable SK.
- (3) If intermittent or poor functioning of the Secondary Seat Stop is reported.
 - (a) Inspect the primary seat latch system for condition and wear.
 - (b) Replace worn or damaged parts.
 - (c) Re-rig the secondary seat stop in accordance with the applicable SK.

5. Airworthiness Limitations

- A. The applicable Model Type Certificate Data Sheet and AFM contain the airframe limitations.
- B. The Secondary Seat Stop system has no mandatory replacement time or life limit associated with its installation and has no impact on the Limitations to the airframe.

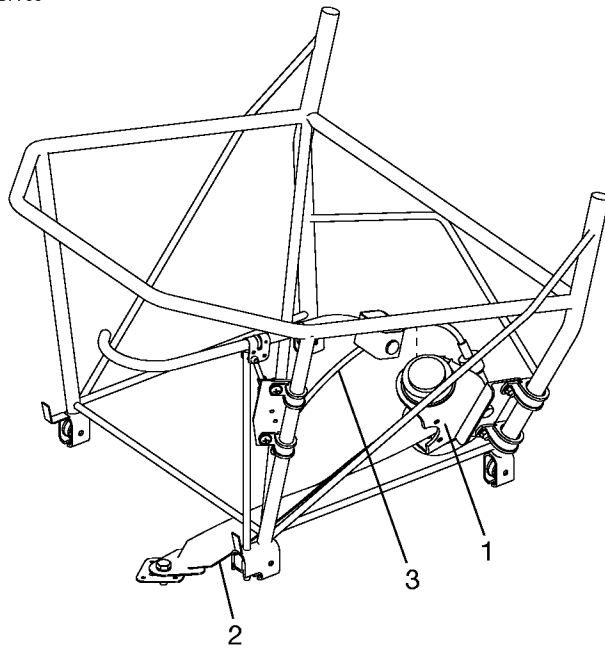

Installation "A"

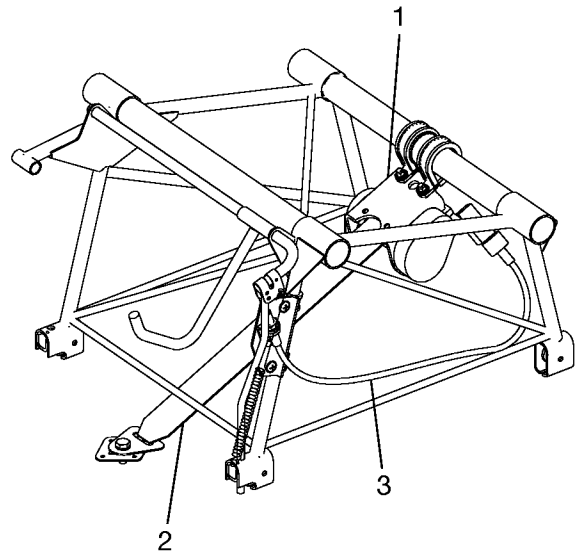

Installation "B"

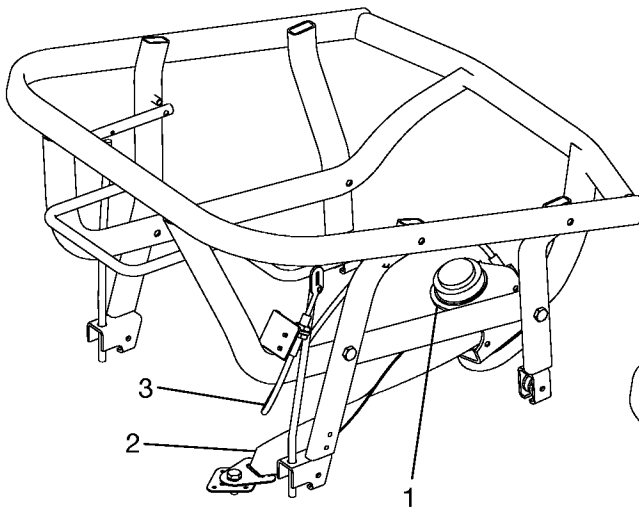

Installation "D"

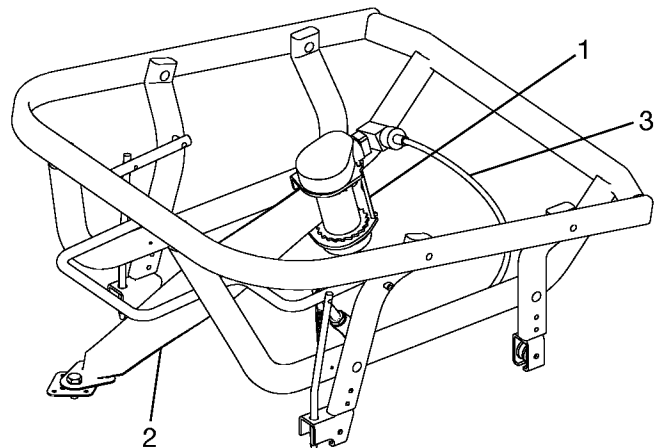

Installation "C"

- 1. Reel
- 2. Belt
- 3. Control Cable

NOTE: All dimensions are shown in inches.

1299T377

Figure 1. Identification of Secondary Seat Stop Installation Configurations (Sheet 1)

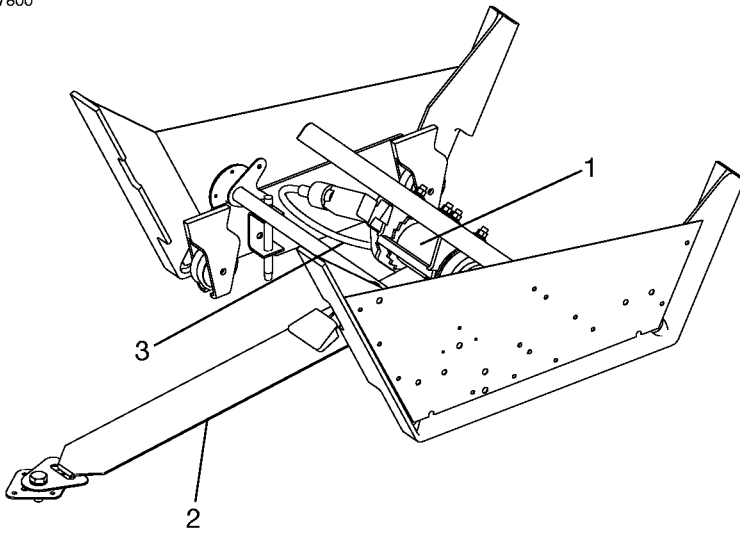

Installation "E"

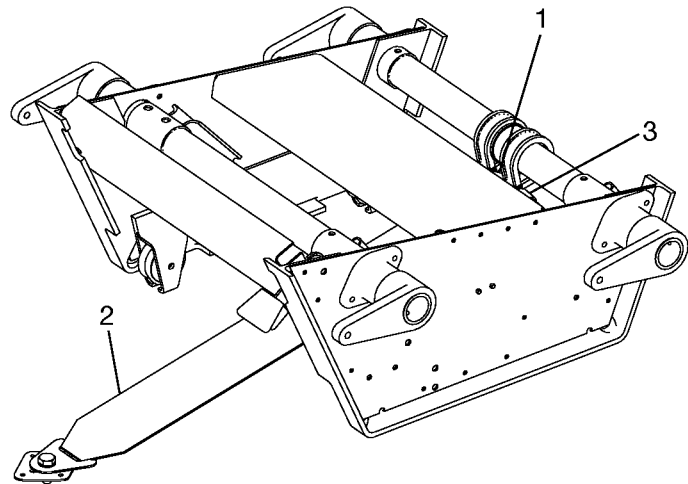

Installation "F"

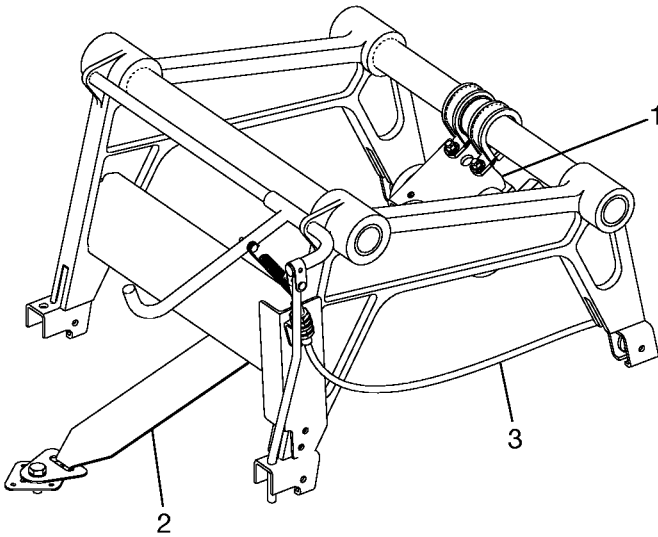

Installation "G"

- 1. Reel
- 2. Belt
- 3. Control Cable

1299T377

Figure 1. Identification of Secondary Seat Stop Installation Configurations (Sheet 2)

B7801

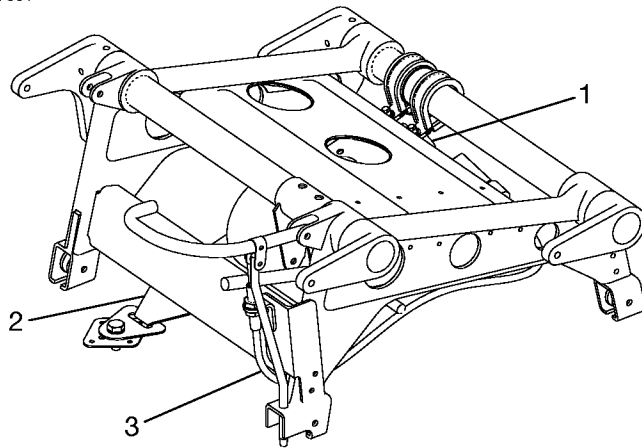

Installation "H"

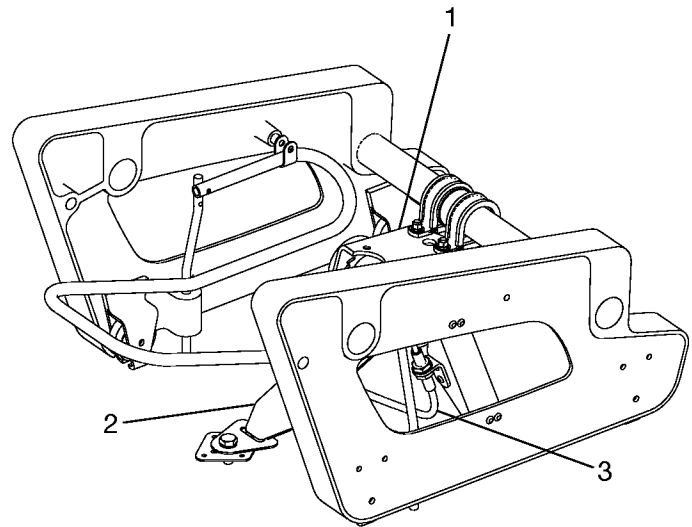

Installation "J"

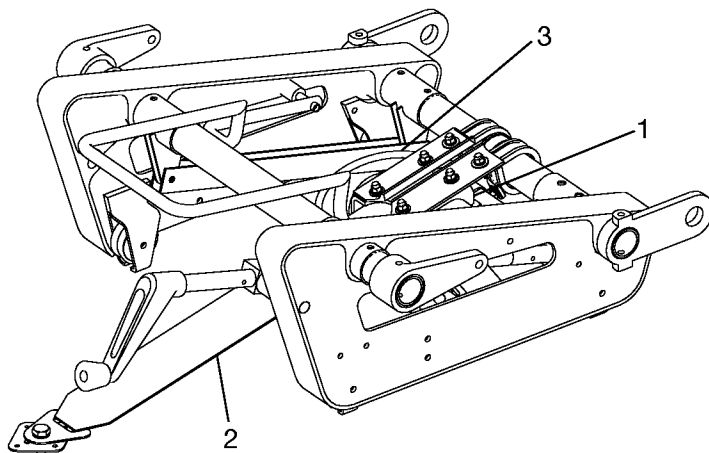

Installation "K"

- 1. Reel
- 2. Belt
- 3. Control Cable

1299T377

Figure 1. Identification of Secondary Seat Stop Installation Configurations (Sheet 3)

B14362

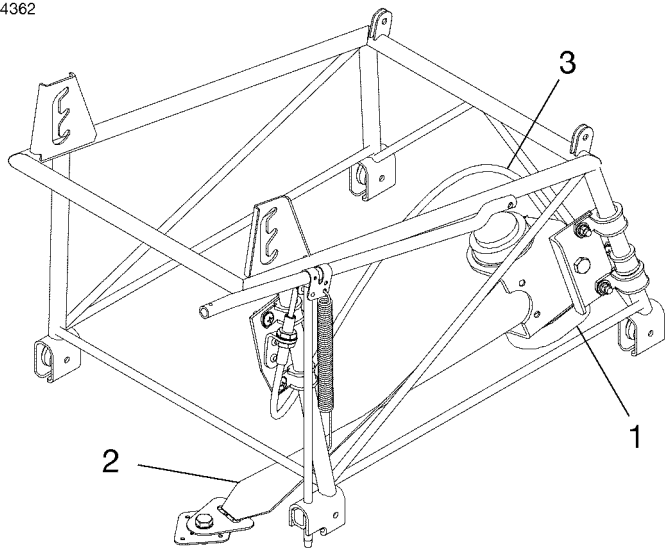

Installation "L"

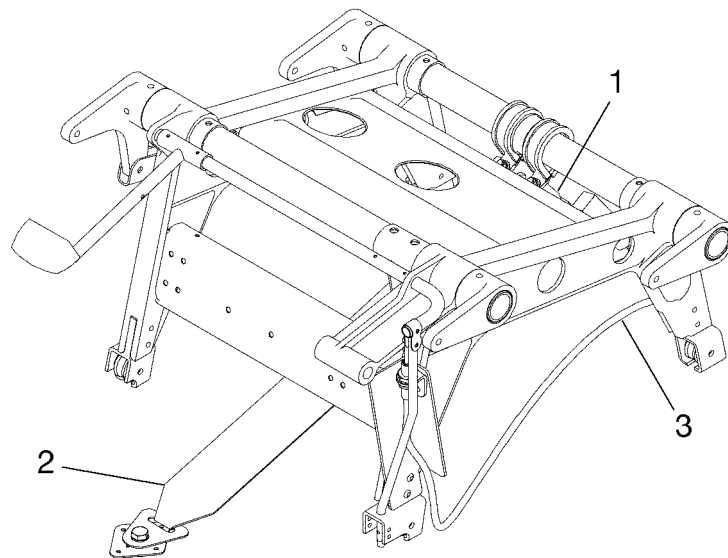

Installation "M"

- 1. Reel
- 2. Belt
- 3. Control Cable

0711041
0700531A

Figure 1. Identification of Secondary Seat Stop Installation Configurations (Sheet 4)

* * * * *

Owner Advisory

October 30, 2018

SEB07-5OAR8

Dear Cessna Single Engine Owner:

This Owner Advisory is to inform you that the parts credit expiration date for Service Bulletin SEB07-5 Revision 6, Pilot and Copilot Secondary Seat Stop Installation is extended to December 31, 2023.

The Secondary Seat Stop is an additional device installed on the pilot or copilot seat that assists in preventing uncommanded rearward movement of the seat. It is designed to assist in providing an additional margin of safety by limiting the aft travel of the seat should the primary seat latch pin(s) not be properly engaged in the seat rail/track. In certain instances, seat slippage could result in some pilots not being able to reach all the controls and/or subsequently losing control of the airplane. The functionality of the Secondary Seat Stop should be completely transparent to the operator. If operation of the seat stop is not transparent the airplane requires maintenance to correct the malfunction of the seat stop mechanism.

Compliance is mandatory for the pilot seat: the secondary seat stop installation shall be accomplished within the next 200 hours of operation or 12 months, whichever occurs first.

Compliance is recommended for the copilot seat: the secondary seat stop installation should be accomplished within the next 200 hours of operation or 12 months, whichever occurs first.

NOTE: This Service Bulletin supersedes Service Bulletin SEB89-2: Pilot Seat Secondary Stop Installation (all revisions).

NOTE: Compliance with Revision 6 is not required if in compliance with the Original Issue or a previous revision. However, if you have not already done so, you must remove and destroy the Instructions for Continued Airworthiness Attachment that is stored in the Technical Library CD-ROM or Maintenance Manual for your airplane and replace it with the Instructions for Continued Airworthiness Revision A that is attached to service bulletin SEB07-5.

Applicable Service Kit parts credit will be provided per airplane to install Service Kits SK195-11A and SK210-174B: Pilot Secondary Seat Stop Installation.

When applicable, freight will be credited at the most economical method unless pre-approved by Cessna.

To receive credit, the work must be completed and a Warranty Claim submitted by a Cessna Authorized Service Facility within 30 calendar days of Service Bulletin compliance before the credit expiration dates shown below.

Domestic	December 31, 2023
International	December 31, 2023

Please contact an Authorized Service Facility for detailed information and arrange to have SEB07-5 Revision 6 accomplished on your airplane.

NOTE: As a convenience, service documents are now available online to all our customers through a simple, free-of-charge registration process. If you would like to sign up, please visit the Customer Access link at www.txtavsupport.com to register.

To obtain satisfactory results, procedures specified in this publication must be accomplished in accordance with accepted methods and prevailing government regulations. Cessna Aircraft Company cannot be responsible for the quality of work performed in accomplishing the requirements of this publication.

