

---

## Service Bulletin

March 22, 1991

SEB91-4

### TITLE

CARGO DOOR LATCH IMPROVEMENT

### EFFECTIVITY

1964 thru 1986 Model 206 and U206 airplanes, normally aspirated and turbocharged models.

MODEL	SERIAL NUMBERS
206	206-0001 thru 206-0275
U206	U206-0276 thru U20607020

### PURPOSE

To provide a modification for installing a return spring in the aft cargo door latch handle assembly and luminescent placards for door handle location and operation.

This modification is designed to assist crew and passengers in operating the aft cargo door from inside the airplane during night operations.

### COMPLIANCE

Recommended; should be accomplished within the next 100 hours of operation or annual inspection, whichever occurs first, or during an equivalent interval for airplanes utilizing the Cessna Progressive Care Inspection program.

### APPROVAL

FAA approval has been obtained on technical data in this publication that affects airplane type design.

### MAN-HOURS

Approximately 5.0 man-hours per airplane.

**MATERIAL**

Required parts are available from the Cessna Supply Division thru an appropriate Cessna Service Station for the suggested list price shown.

<b>PART NUMBER</b>	<b>DESCRIPTION</b>	<b>QTY./AIRPLANE</b>	<b>PRICE</b>
SK206-40	Cargo Door Latch Improvement Kit	1	\$ 579.00 (A) ea.

ALL PRICES SUBJECT TO CHANGE WITHOUT NOTICE

**ACCOMPLISHMENT INSTRUCTIONS**

SK206-40 Cargo Door Latch Improvement instructions are attached.

**CREDIT**

Not Applicable.

**OWNER NOTIFICATION**

On April 5, 1991 the following Owner Advisory message will be sent to applicable owners of record in SEB91-4A.

Dear Cessna Owner:

A modification for installing a return spring in the aft cargo door latch handle assembly and luminescent placards for door handle operation and location are now available for your airplane. This modification is designed to assist crew and passengers in operating the aft cargo door from inside the airplane during night operations.

Compliance is recommended; should be accomplished within the next 100 hours of operation or annual inspection, whichever occurs first, or during an equivalent interval for airplanes utilizing the Cessna Progressive Care Inspection program.

Please contact a Cessna Single Engine Service Station and arrange to have this Service Kit installed on your airplane.

\* \* \* \* \*



# Service Kit

DATE March 22, 1991

SK206-40

TITLE CARGO DOOR LATCH IMPROVEMENT.

The following procedures provide instructions to replace the aft cargo door handle and add a return spring to the aft cargo door handle. Install a new operational placard on the forward cargo door and add an additional placard on the aft cargo door pointing out the handle location.

## EFFECTIVITY

### MODELS AFFECTED

206  
U206

### SERIALS AFFECTED

206-0001 thru 206-0275  
U206-0276 thru U20607020

## PARTS LIST

QUANTITY	PART NUMBER	NOMENCLATURE
4	MS20426AD4-4	Rivet
12	S1021A8-8	Screw
1	1291381-2	Handle
1	1291381-3	Placard Assy
1	1291381-6	Spring
1	1291381-7	Doubler
1	1291381-8	Placard
1		Instructions

## CHANGE IN WEIGHT AND BALANCE

MODEL ..... 206/U206

WEIGHT CHANGE ..... Negligible

## ACCOMPLISHMENT INSTRUCTIONS

- A. Cargo door latch improvement.
1. (Refer to Figure 1, Sheet 1 thru 3) Remove upholstery panel and trim panel on aft cargo door to gain access to remove door handle assembly. Retain panel and hardware.
  2. Remove existing door handle (3) on aft cargo door (9). Discard handle, retain hardware.
  3. (Refer to Figure 1, Detail C & View E-E) Place doubler (5) in position on aft side of fwd door channel face per dimensions shown. Using existing holes in doubler (5) as a template, drill and countersink holes (8).

# SERVICE KIT

---

**SK206-40**

4. Secure doubler (5) to door channel (15) using rivets (8).
  5. Locate and drill hole (16) in door channel (15) per dimensions shown in detail C and view D-D. Deburr hole.
  6. Install new door handle (11) using retained hardware. Install spring (10) as shown using existing hole in handle and hole drilled in door channel. Refer to chapter 3 in the 206 Service Manual for rigging procedures if required. Handle should retract to locked position when released with door open.
  7. Replace upholstery panel on aft cargo door with retained hardware removed in step 1.
  8. Place placard (6) in position as shown. Using existing holes in placard as a template, mark and drill holes (7) thru door channel (15) and doubler (5).
  9. Install placard (6) to upholstery panel, doubler and door channel using screws (7).
  10. Place placard (13) in position on fwd cargo door (12) per dimensions shown. Mark and drill holes (14) using existing holes in placard as a template. Remove placard, clean and deburr holes.
  11. Install placard (13) and secure with existing screw (4) and screws (14).
- B. Make an entry in the airplane logbook stating this Service Kit has been installed.

# SERVICE KIT

SK206-40

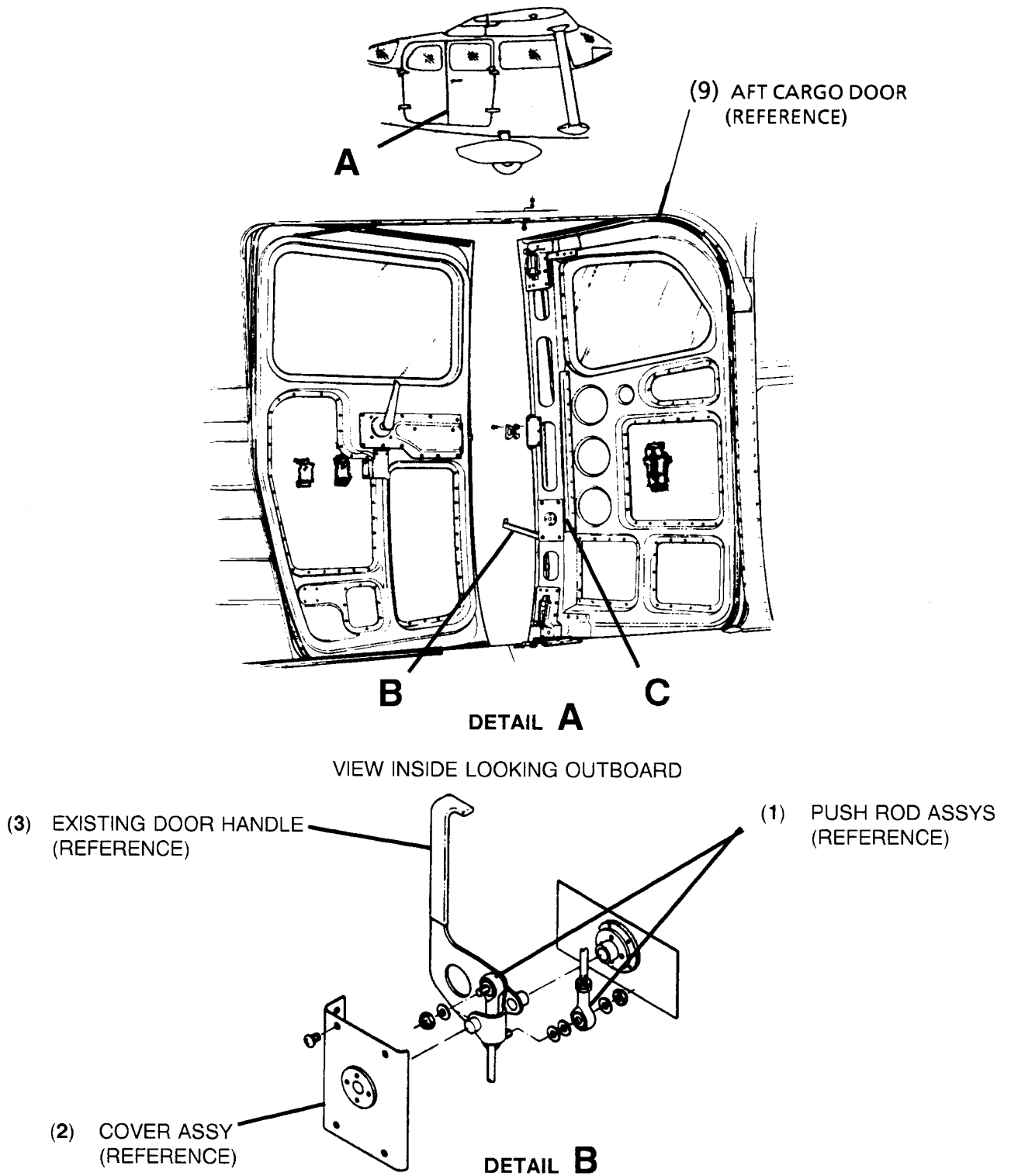
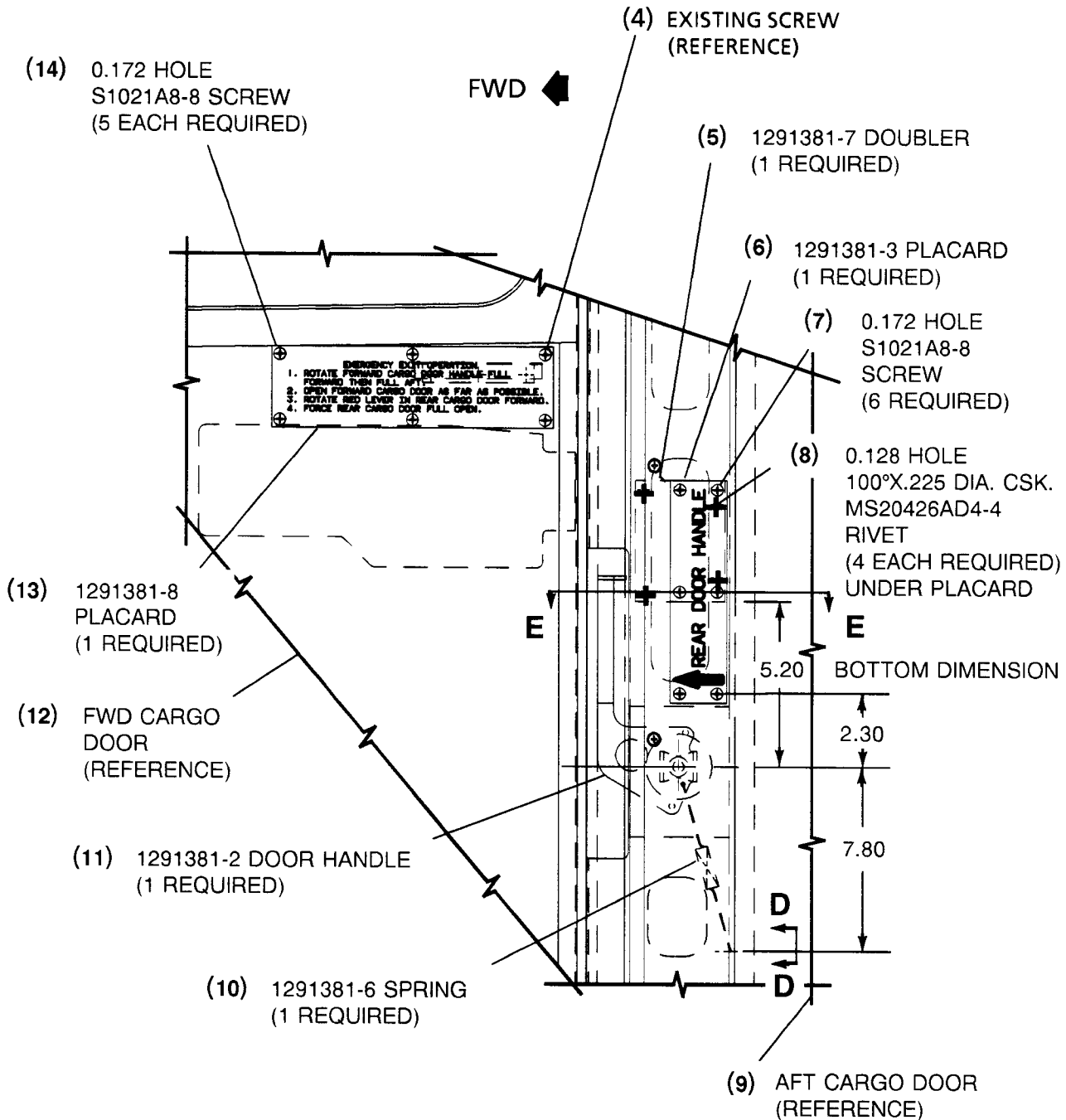

Figure 1. 206 Cargo Door Latch Improvement (Sheet 1 of 3)

# SERVICE KIT

SK206-40



## DETAIL C

AFT CARGO DOOR HANDLE- INSIDE LOOKING OUTBOARD

Figure 1. 206 Cargo Door Latch Improvement (Sheet 2 of 3)

# SERVICE KIT

SK206-40

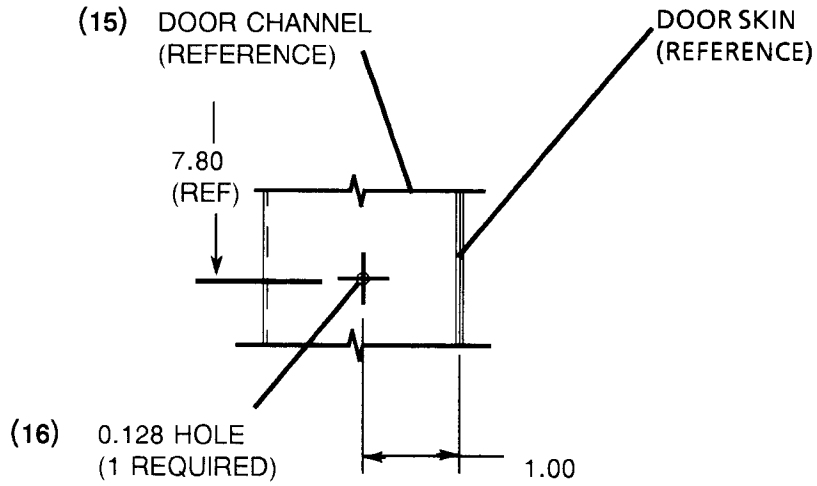

VIEW D-D

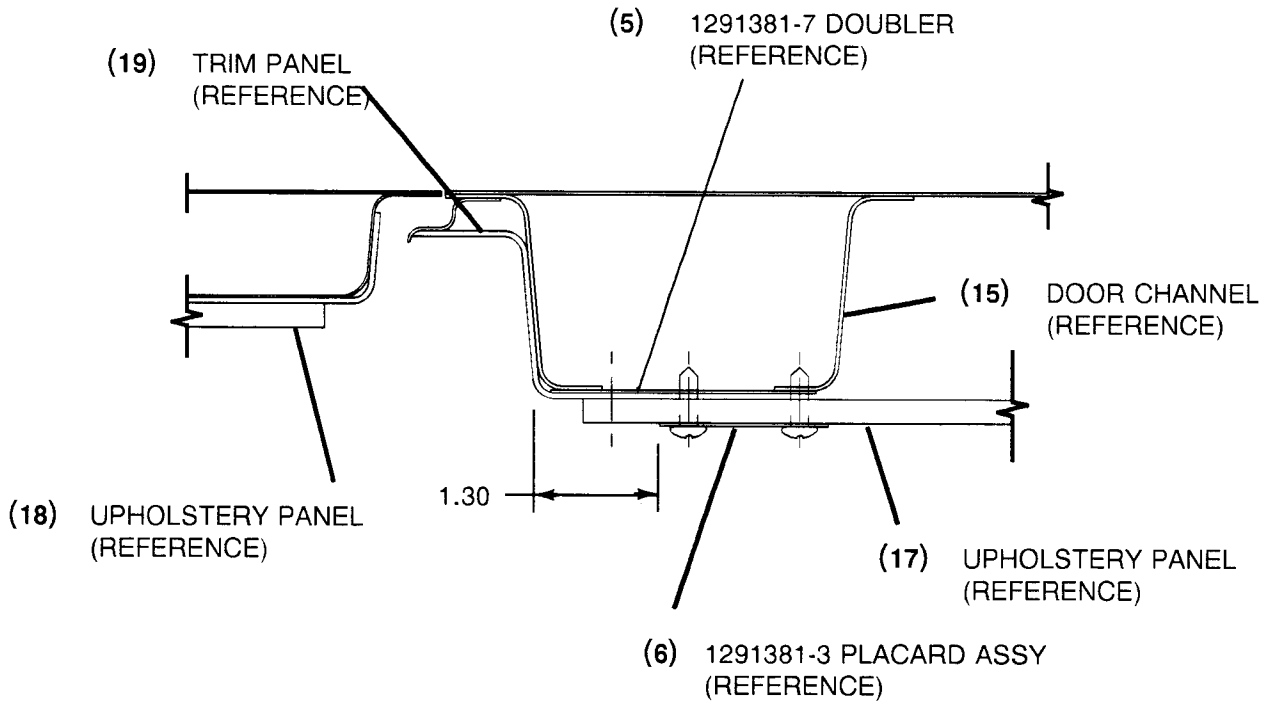

VIEW E-E

Figure 1. 206 Cargo Door Latch Improvement (Sheet 3 of 3)